



a place to call home:

**Could you be eligible
for a free solar electric
system on your roof?**

**Wakefield Mega
Solar Scheme**

**Evaluation of the Wakefield Mega Solar
project by Wakefield Council**

Paul Rogers and Michael Hamer



Action for Warm Homes

Background

National Energy Action (NEA) is the national fuel poverty charity working across England, Wales and Northern Ireland, and with sister charity Energy Action Scotland (EAS). NEA works to eradicate fuel poverty and campaigns for greater investment in energy efficiency to help those who are poor or vulnerable to be able to stay affordably warm. NEA works in partnership with central and local government, fuel utilities, housing providers, consumer groups and voluntary organisations, to promote energy efficiency with the aim of bringing social, environmental, housing and employment benefits to communities.

NEA achieves its objectives through:

- Developing and managing practical projects which demonstrate innovative ways of tackling fuel poverty and bringing the wider benefits of energy efficiency to communities.
- Carrying out research and analysis into the causes and extent of fuel poverty and the developing policies which address the problem.
- Providing advice and guidance on good practice in delivering energy efficiency services to low-income householders.
- Developing national qualifications and managing their implementation to improve the standards of practical work and the quality of energy advice.
- Campaigning to ensure social and environmental objectives are brought together under national energy efficiency programmes.

This project was carried out by the Innovation and Technical Evaluation team at NEA:

Paul Rogers, Senior Innovation and Technical Evaluation Coordinator
Michael Hamer, Innovation and Technical Evaluation Manager
Chris Rogers, Innovation and Technical Evaluation Consultant

July 2023

National Energy Action
Level 6 (Elswick)
West One
Forth Banks
Newcastle upon Tyne
NE1 3PA
www.nea.org.uk



Action for Warm Homes

Acknowledgements

Funding for this project was provided by Wakefield District Council

We would also like to thank our project partners:

Wakefield Council

Mark Hooton, Senior Strategic Housing Manager

Sarah Johnson, Energy Project Manager, Home Energy Team

Bobbie-Jo Singleton, Energy Project Officer, Home Energy Team

ASK Renewables

Antony Stewart

Samantha Kidd



Table of contents

| | |
|--|----|
| Background..... | 2 |
| Acknowledgements..... | 3 |
| Table of contents..... | 4 |
| 1. Project overview..... | 10 |
| 1.1. Introduction..... | 10 |
| 1.2. Context..... | 10 |
| 1.3. Solar PV systems..... | 12 |
| 1.4. Estimating annual solar PV generation..... | 13 |
| 2. Installation programme..... | 16 |
| 2.1. Recruitment of households for installations..... | 16 |
| 2.2. Recruitment of households for evaluation..... | 16 |
| 2.3. Installations..... | 17 |
| 2.4. Characteristics of the monitored sites..... | 21 |
| 2.5. Characteristics of the monitored households and satisfaction with the installation..... | 23 |
| 3. Monitoring of installations..... | 33 |
| 3.1. LuxPower LXP hybrid inverter..... | 33 |
| 3.2. LuxPower monitoring..... | 35 |
| 3.3. Factors affecting the monitoring..... | 38 |
| 4. Technical evaluation and results..... | 39 |
| 4.1. Details of monitored properties and their installations..... | 39 |
| 4.2. Performance of the solar PV systems..... | 42 |
| 4.3. Self-consumption of the solar generation..... | 45 |
| 4.4. Impact of adding battery storage..... | 48 |
| 4.5. Cost savings from the solar PV and battery systems..... | 51 |
| 5. Conclusions..... | 54 |
| 6. Appendix..... | 57 |
| 6.1. Appendix 1 - Wakefield Council recruitment letter..... | 57 |
| 6.2. Appendix 2 – Information sheet for NEA project evaluation..... | 63 |
| 6.3. Appendix 3 - Data sheet for LuxPower LXP3600 hybrid inverter..... | 66 |



Executive Summary

Introduction

The Wakefield Mega Solar project was funded through phase 2 of the Green Homes Grant Local Authority Delivery (LAD) scheme in partnership with the North East Yorkshire and Humber Energy Hub. There were 115 solar PV installations installed between October 2021 and September 2022.

The project was led by Wakefield Metropolitan District Council, with project management by Equans and solar PV installations by ASK Renewables. National Energy Action (NEA) was asked to carry out an evaluation of the project and also assisted the Council by adapting NEA's solar PV advice leaflet for this project.

There were an estimated 26,170 households (17.3%) in fuel poverty in Wakefield District in 2020 prior to the energy crisis. There were an estimated 88,300 homes in EPC band D in Wakefield District along with 22,414 (13.4%) in band E and 5,174 (3.1%) in bands F and G.

The project

The Wakefield Mega Solar project aimed to improve the EPC score for low-income households living in homes with poor energy efficiency. This was to be achieved primarily by installing solar PV systems with average funding of up to £10,000 available for installations for owner-occupiers.

Households living in EPC band E, F and G properties were sent a recruitment letter offering free solar PV installations. To qualify, households needed to meet all the below criteria:

- You are a homeowner (owner-occupier) living in the Wakefield district
- Your total annual household income is £30,000 GROSS or less (including all benefits)
- You live in a domestic house or bungalow with its own pitched roof and loft access.
- Your home has a poor energy efficiency rating (Band D-G), shown via a valid Energy Performance Certificate (EPC)
- You will need to have cavity wall and loft insulation (where applicable), but where this is not installed, help may be available.

Properties in EPC band D were initially put on a waiting list. This was to assist in limiting the number of properties receiving installations in EPC band D to less than 50% of the total.

Wakefield Council wanted an evaluation of the Mega Solar project, which would verify the benefits provided to households from the solar PV installations. The Innovation and Technical Evaluation team at NEA was asked to undertake this task. 28 households were recruited to take part in the evaluation.

These households had a more expensive LuxPower hybrid inverter installed with the solar PV system. This allowed the households to monitor the solar generation and household consumption as well as provided valuable data to the evaluation team at NEA. The hybrid inverter also allowed battery storage to be installed more easily and 4 of the monitored households subsequently funded installation of battery storage systems.



Installations

The 115 installations in the Wakefield Mega Solar programme took place between 14 Oct 21 and 20 Sep 22. A LuxPower LXP3600 hybrid inverter was fitted with 28 (24.3%) of the solar PV installations. This provided monitoring of the solar PV generation, PV export and household consumption. The remaining solar PV installations had standard string inverters from either Solis or SolaX and the model was dependent on the PV system size.

The panels installed were half-cell modules and either manufactured by JA Solar or Longi. The rated power of the panels ranged from 370W to 385W. 80% of the installations had between 8 and 10 solar panels. Only 17 of the installations (14.8%) had smaller arrays of between 4 and 6 solar panels. There were 99 installations where the solar panels faced a single direction and the remaining 16 had the panels split across 2 faces of the roof.

Out of the 115 installations, 68 (59.1%) had an estimated annual generation of between 2,500 and 3,500 kWh. There were also 23 installations (20%) with an estimated annual generation of between 1,000 and 2,000 kWh.

Characteristics of the monitored sites

There were 28 properties in the monitored group for the evaluation. 17 of these properties were semi-detached houses, 4 were detached houses and 4 were terraced houses (mid or end). There were also 3 bungalows, with 2 of these being semi-detached.

Space heating was provided by a gas boiler for 24 out of the 28 properties. Among the rest, 2 used storage heaters and there was a property with a coal boiler and another classed as having a solid fossil fuel boiler.

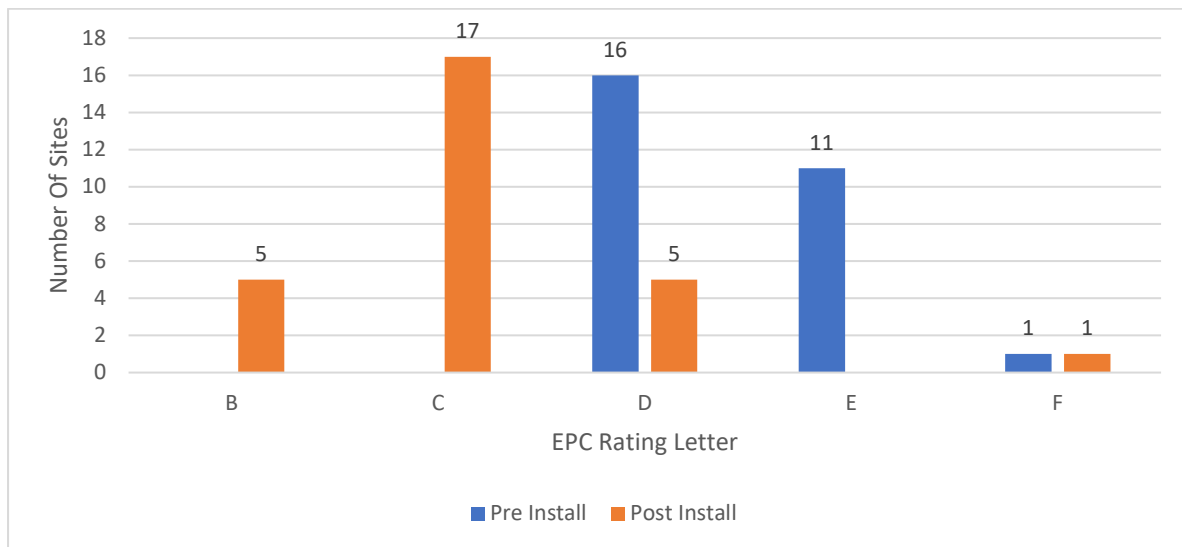

Figure E1 Change in EPC band for the 28 properties in the monitored group

Before the installations, there were 16 properties in band D in the monitored group, 11 properties in band E and a single property in band F. After the installations, 5 of the properties were now in EPC band B, 17 in band C and 5 properties in band D. The property in band F saw an improvement in the EPC score, but not enough to increase the band. Among the monitored properties, the EPC score rose from an average of 56.4 to 72.2 after the solar PV systems were installed.



Satisfaction with the installations

Out of the 28 households in the monitored group, 24 completed an online questionnaire. Topics covered included characteristics of the households, their behaviour, their satisfaction with the solar PV installation and perception of the benefits provided.

19 of the 24 households rated the installation of their solar PV system 'very good' with 4 considering it 'good' and a single household thought it was 'average'. Out of the 24 households who completed the survey, 23 said they were happy with the solar PV system and would recommend a similar installation to their friends.

22 of the 24 households used the monitoring app for the LuxPower inverter and 14 of the households used it at least once a day. They typically used the app to see their electricity use and the solar generation and to know when it was best to use high power appliances like washing machines.

The monitored group of households typically spent a lot of time at home and so were more likely to make use of the solar generation. 18 said they were at home all day and 6 said they were in half the day. 17 of the households thought they were saving a lot with the solar panels, 6 thought they were saving a little and a single household was not sure.

Households were more aware of how they used electricity and there was also behaviour change. 23 of the 24 households were more aware of their electricity use and 21 of the households had changed how they used electricity. 19 of the 24 households tried to use high power appliances when it was sunny outside. 18 tried to use appliances in the daytime rather than at night and 14 tried to use high power appliances one at a time. There were also other general energy saving behaviour changes like switching off appliances and using the heating less.

Smart meters were common among the households with 20 out of the 24 who completed the questionnaire having a smart meter. All of those interviewed with a smart meter were aware of the Smart Export Guarantee. There were mixed experiences with the export tariff, with several not signing up as the tariff offered by their electricity supplier was considered too low. Others commented on the difficulty and length of time it took to sign up.

There were many positive comments about the project from interviewed households. These included: "Everything from start to finish was 100% fantastic! From the local authority to the company that fitted them who I must say went above and beyond absolutely brilliant!! The men that fitted them were also amazing what more can I say!"

There were also a few negative comments. These included a comment on there being too much red tape. One household thought they had seen little benefit moneywise and thought the panels were not effective when the sun was not shining. This household had issues with the monitoring and it had not been working for over a year. A household commented on a cracked tile, while another said the scaffolding had been left up too long.

Monitoring of the installations

Households in the monitored group had a LuxPower LXP3600 hybrid inverter fitted as part of the solar PV system. This had a monitoring system with a Wi-Fi dongle that connected to the internet and provided performance data to the LuxPower View app and the LuxPower Monitor Centre portal. The inverter measured the solar generation, while a CT clamp was fitted on the household electricity supply and allowed the hybrid inverter to measure the household import/export.



Figure E2 Summary and current system information from Monitor section of LuxPower portal

Installing a hybrid inverter also meant it was easier for households to add battery storage to the solar PV system. Over the duration of the project, 4 of the 28 households installed their own battery systems to improve their savings from the solar PV system.

There were problems with the LuxPower monitoring which limited the amount of useful data that could be analysed. This was caused by households switching broadband router, smart meter installers replacing the CT clamp for the inverter in the wrong orientation and issues with the CT clamp or cable which meant the measured household consumption was not accurate and followed the solar generation.

There were also accuracy issues with the LuxPower monitoring. Comparing the generation recorded by the LuxPower monitoring with a reading from a generation meter showed the meter reading was 10.4% lower than the reading from the LuxPower monitoring.

Technical evaluation

Out of the 28 monitored installations a number of them were offline for extended periods or there were other issues with the monitoring. As a result, there were only 21 installations which had a 12-month period of good data for analysis.

The annual solar generation measured by the LuxPower monitoring ranged from 1,377kWh for a 1.5kW system to 4,299kWh for a 3.8kW installation. Out of the 21 installations analysed, the annual generation measured for 18 of the installations was higher than the estimated annual generation by the installer. Even if the LuxPower monitoring overestimated the generation by 10% on all the systems, the annual generation would still outperform the installer estimate on 12 of the 21 installations.

The total generation measured by the LuxPower monitoring over a year for the 21 installations was 63,937kWh. This compares to a total of 55,818kWh for the installer estimates. The total carbon equivalent saving for the 21 installations over the year was 12.36 tonnes.

The level of self-consumption of the solar generation was calculated for the 21 households based on the LuxPower data. There were 2 households where the self-consumption was



under 10% (5.9% and 7.8%). Both these households had low levels of household consumption and were in half of the day.

There were 3 households which had battery storage where monitoring data was available for a year. These had levels of self-consumption between 50% and 60%. There were other households with high levels of self-consumption of 35-55%. These households were typically at home all day and had high levels of household consumption.

The 4 households that added battery storage to their solar PV installations fitted systems with a usable battery capacity of between 2.2kWh and 9.6kWh. 3 of the batteries charged from excess solar generation with occasional grid charging to avoid the battery charge level becoming too low. These battery systems were analysed between 1 Jun 22 and 31 May 23. The battery charge for the 3 systems was 251, 598 and 670kWh. The reason for the low level of charge on one of these systems was due to installation of the battery on 17 Oct 22, part way through the monitoring period.

The largest battery (9.6kWh) was fitted on 6 Oct 22, but there was limited monitoring data available for this household due to issues with the CT clamp prior to 26 Jul 22 and the system losing internet connection after 16 Apr 23. The household was on an Economy 7 electricity tariff and charged from low-cost electricity overnight as well as from the excess solar generation. This meant between 6 Oct 22 and 16 Apr 23, the battery charge was 1,781kWh. The self-consumption of the solar generation was 42.0% and 58.7% in Aug and Sep 2022, before the battery was installed. For the months Oct 2022 to Mar 2023 where the battery was operating, the self-consumption had increased to between 86.7% and 91.9%.

An assessment of the cost savings from the solar panels was made using the LuxPower monitoring data for the 21 analysed installations. This used an electricity unit rate of 30p/kWh. The annual electricity savings ranged from £46.83, for one of the households with low self-consumption to £668.58, for the household with the highest solar generation. The 3 households with batteries that were monitored over the year also had high savings which were in the range £471.84 to £583.56.

Estimates were also made of the payments that would have been received from the Smart Export Guarantee (SEG). Export tariff rates offered by suppliers varied from less than 3p/kWh to 15p/kWh or more. For this analysis a tariff rate of 5p/kWh was used. Export payment varied from £30.59 to £157.92. The lowest export payment was for the household with the smallest solar PV installation which also had a high rate of self-consumption. The households with batteries also had low export payments which were under £70. The households with the highest export payments had higher levels of solar generation and lower self-consumption. If the household with the highest export was on the most generous SEG tariff, the export payment could have been as high as £473.76.

Households might consider making greater use of the solar generation in the home if the SEG tariff rate is not attractive. Options could include battery storage or solar diverters such as solar immersion controllers which heat the domestic hot water through the immersion heater, utilising unused solar generated energy.



1. Project overview

1.1. Introduction

The Green Homes Grant Local Authority Delivery (LAD) scheme was a £500m scheme which funded energy efficiency and low carbon heating projects for low-income households across England. In phase 2 of the scheme, there was £300m allocated to the 5 Energy Hubs across England to work with regional local authorities to deliver energy efficiency improvements¹.

The Wakefield Mega Solar project was funded through phase 2 of the Green Homes Grant LAD scheme in partnership with the North East Yorkshire and Humber Energy Hub. There were 115 solar PV installations completed between October 2021 and September 2022.

The project was led by Wakefield Metropolitan District Council, with project management by Equans and solar PV installations by ASK Renewables. National Energy Action (NEA) was asked to carry out an evaluation of the project and also assisted the Council by adapting NEA's solar PV advice leaflet for this project.

1.2. Context

Wakefield District has an area of 339km² with 70% classed as green belt. The largest settlement is the City of Wakefield, and the district includes other towns such as Castleford, Knottingley, Normanton, Ossett and Pontefract. The population in 2021 was 353,802 and earnings were below the average regional and national rates. There were an estimated 26,170 households (17.3%) in fuel poverty in Wakefield District in 2020 prior to the energy crisis².

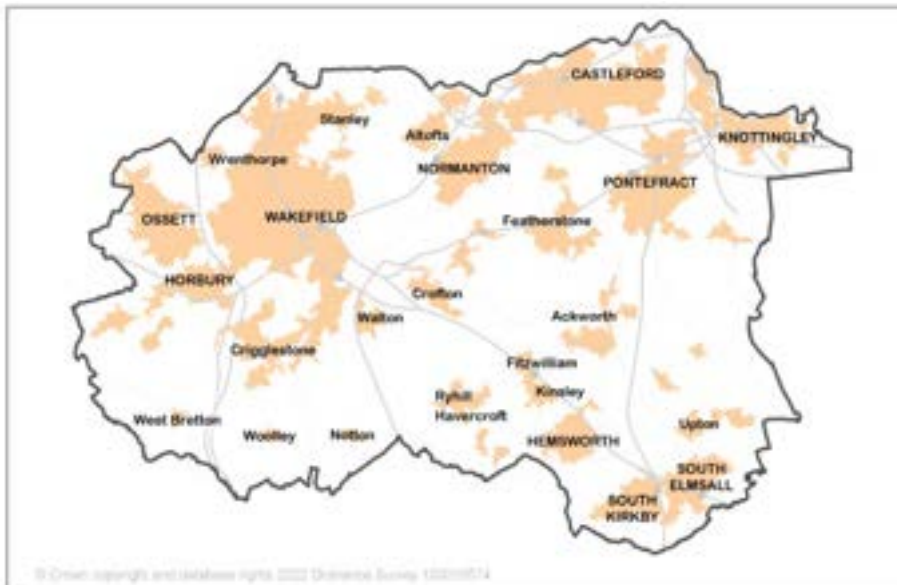

Figure 1.1 Map of the Wakefield District

¹ Green Homes Grant Local Authority Delivery, <https://www.data.gov.uk/dataset/82658bdd-1ffa-42c8-a401-cc012b397a76/green-homes-grant-local-authority-delivery> (Accessed 23 May 2023)

² Wakefield – State of the District, Annual Report 2023, <https://www.wakefield.gov.uk/media/0jojvxxv/state-of-the-district-2023-web.pdf> (Accessed 23 May 2023)



Action for Warm Homes

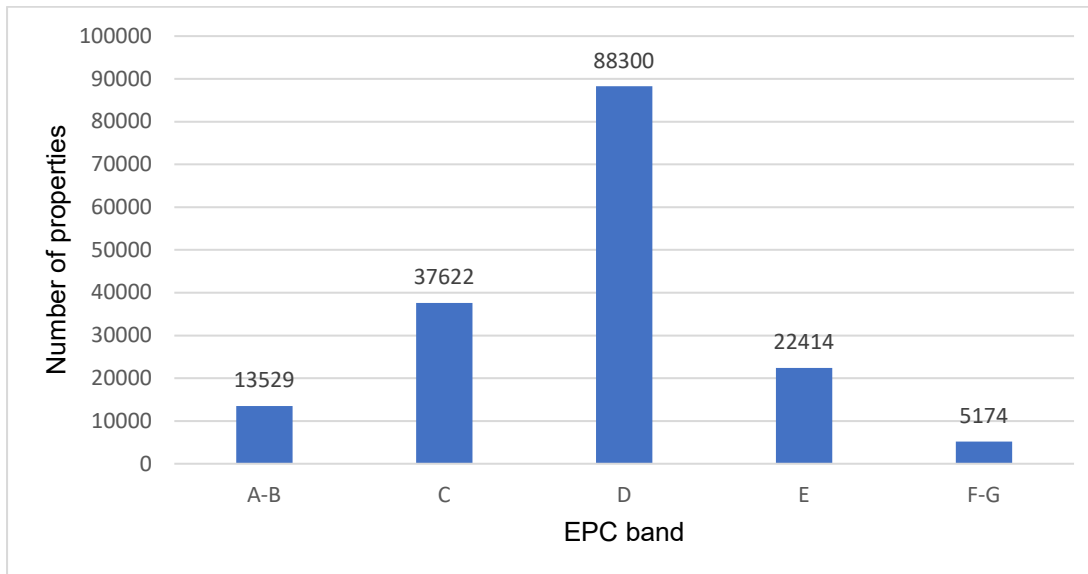

Figure 1.2 Estimated numbers of domestic properties in different EPC bands in Wakefield District

Wakefield District Council has estimates of the number of domestic properties in different EPC bands. This is based on data from the EPC register and modelling of homes without EPCs³. There were about 88,300 EPC band D properties in Wakefield District, the most of any EPC band. About 22,414 domestic properties (13.4%) were in EPC band E and 5,174 (3.1%) in bands F and G.

Details of the Green Homes Grant LAD scheme phase 2 were as follows⁴:

- Households receiving measures should have a combined household annual income of no more than £30,000 gross before housing costs and including benefits
- Funding must support the retrofit of existing domestic dwellings only
- Properties in EPC bands E, F and G were targeted, but up to 50% of band D properties could be considered for inclusion in the project
- For owner-occupiers, households were not expected to contribute towards costs of upgrades and the costs of measures was not expected to exceed £10,000 per property
- For rented properties, the minimum contribution from the landlord towards the cost of measures was one third and the average subsidy was should not exceed £5,000 per property
- Eligible measures include energy efficiency and heating measures compatible with the Standard Assessment Procedure (SAP) which would help improve EPC band D-G homes. This included technologies such as insulation and solar PV technology

The Wakefield Mega Solar project focused on solar PV as an effective method to raise the EPC score of the targeted homes and help reduce energy bills.

³ Personal communication, Sarah Johnson, Energy project manager, Wakefield Council, (17 May 2023)

⁴ Green Homes Grant: Local Authority Delivery, Phase 2 Guidance for Local Authorities, North East Yorkshire and Humber Energy Hub, <https://www.neynetzerohub.com/wp-content/uploads/2021/03/LAD2-LA-GUIDANCE.pdf> (Accessed 23 May 2023)

1.3. Solar PV systems

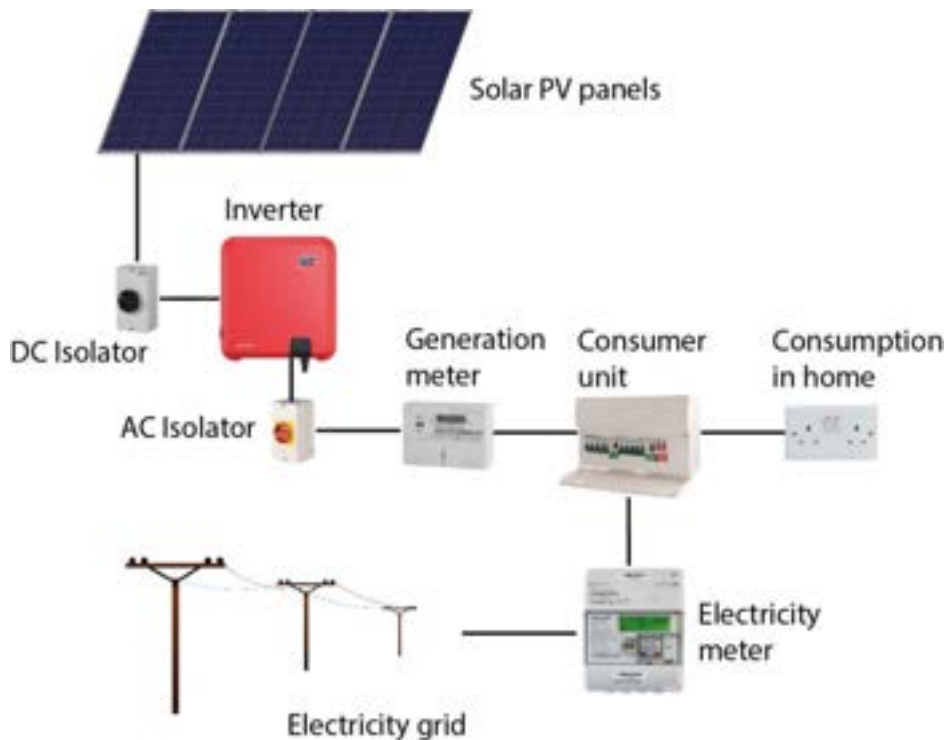

Figure 1.3 Schematic diagram of components in a domestic solar PV system

A domestic solar PV system consists of a number of components. There are the solar panels which generate direct current (DC) electricity. An inverter converts the DC electricity from the solar panels into AC (alternating current) electricity for use in the home. Some inverters are known as hybrid inverters, and these can act as the inverter for both the solar panels and a battery. While most modern solar PV inverters are capable of monitoring the solar generation, a hybrid inverter is also able to record the PV generation, PV export and electricity import from the grid. In order to do this, it usually has a current transformer (CT clamp) or meter to measure the current to and from the grid. Monitoring data is usually accessed via a monitoring portal or app. For data to be recorded, it is necessary for the inverter to have an uninterrupted connection to the internet.

There are isolator switches on both the DC and AC side of the inverter so that an electrician is able to work on the solar PV system or home electrics without the risk of an electric shock. There is also a generation meter fitted with the solar PV system and this provides a means of recording cumulative generation from the solar PV system. Comparing regular meter readings with the expected generation allows system owners to assess whether the PV system is performing as expected.



1.4. Estimating annual solar PV generation

The annual generation from a domestic solar PV system will depend on a number of factors⁵:

- Size of the solar PV array (kW)
- Orientation of the solar PV array
- Inclination of the solar PV array
- Shading of the solar panels
- Location
- Solar irradiance that year
- Components used for the solar PV system

The orientation and inclination of the solar panels affects the level of solar energy reaching the panels. In the UK, maximum annual generation will occur for a solar array that faces south on a roof inclined at about 35 degrees.

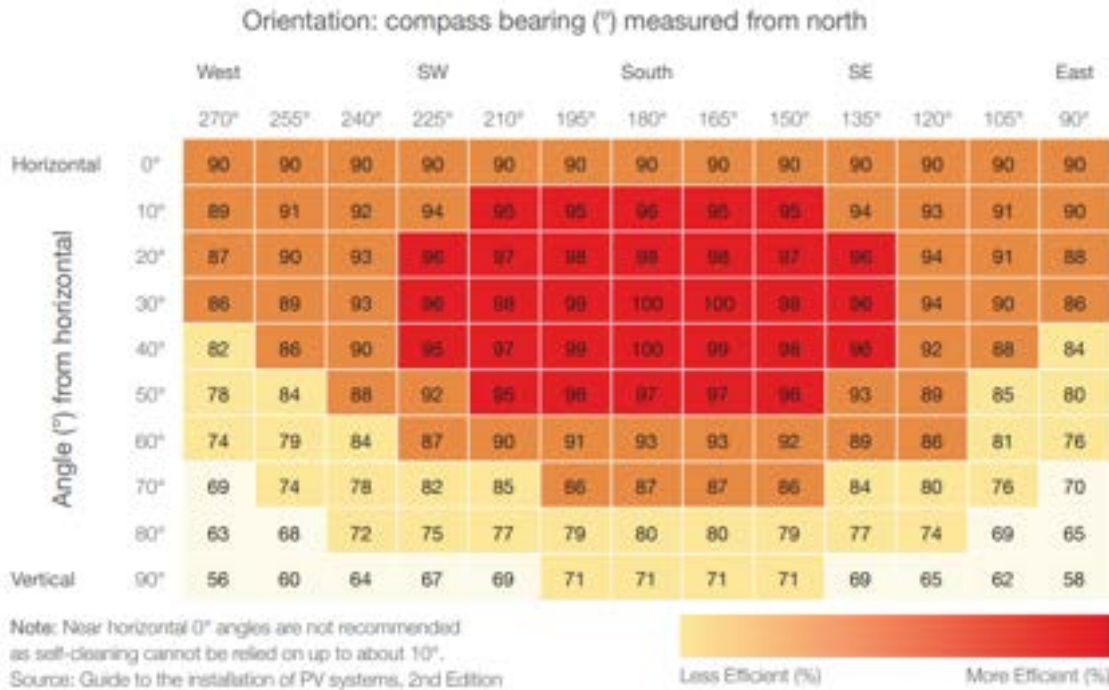

Figure 1.4 Percentage of the maximum possible yield from a solar PV system in the UK for different orientations and inclinations (Graphic from Mitsubishi Electric Information Guide, Photovoltaic Systems, Issue 40)

The sun rises in the east and a solar PV array facing east will typically have a peak in electricity generation before midday. A south facing solar PV array will generate maximum electricity at about midday. The peak in generation will be higher than for a comparable sized east or west facing PV array. A west facing solar PV array will tend to generate maximum electricity later in the afternoon.

⁵ Rogers and Hamer (NEA, 2023), Increasing self-consumption of solar PV: Analysis of long-term performance of domestic solar PV installations, <https://www.nea.org.uk/publications/increasing-self-consumption-of-solar-pv-long-term-pv-analysis/> (Accessed 12 Jun 2023)

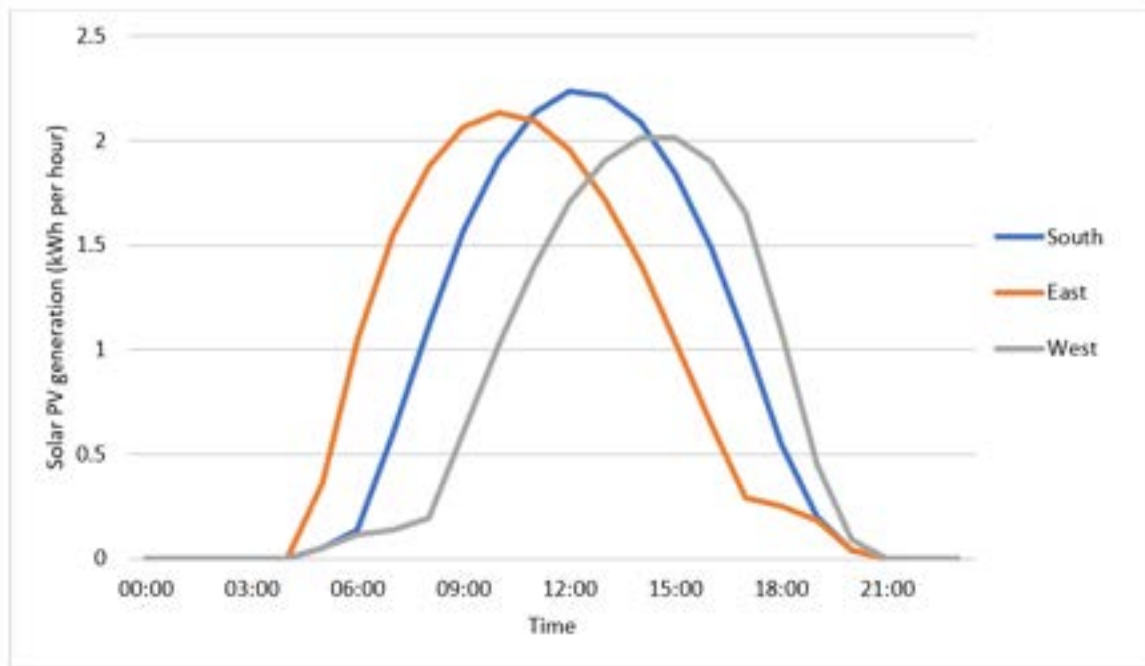

Figure 1.5 Illustration of how solar PV generation can vary on a sunny day for different orientated solar PV arrays

Solar panels are normally fitted on the roof of the house on the side which faces closest to south. Sometimes if the roof has aspects facing approximately east and west, installers may fit the solar panels on both faces of the pitched roof. Figure 1.5 shows examples of how the solar generation can vary on a sunny day if the array faces south, east or west.

While a south facing PV array will generate more electricity over a year, an east/west facing array will generate more electricity in the morning and afternoon when households are likely to be using more electricity. This means the level of self-consumption of the solar generated electricity could be higher for households with an East-West solar PV array.

Shading of solar panels can come from trees or bushes or a nearby building. It can also be caused by chimneys or other features of the property producing a shadow on some of the solar panels at a particular time of day. A string inverter has the solar panels wired together in series in one or two strings. If there is shading or significant dirt on a panel in a string and the power output from the panel is reduced as a result, other panels in the string will be similarly affected.

There are several recognised ways installers make estimates of the annual solar generation from a PV system⁶. The MCS method is typically used for quotes for PV systems registered with the Microgeneration Certification Scheme. There is also a free to access website called PVGIS which has been developed by the EU Science Hub. Installers frequently use a more advanced software package called PV*SOL, which will take into account factors such as the models of solar panels and inverter when estimating the generation.

⁶ Rogers and Hamer (NEA, 2023), Increasing self-consumption of solar PV: Analysis of long-term performance of domestic solar PV installations, <https://www.nea.org.uk/publications/increasing-self-consumption-of-solar-pv-long-term-pv-analysis/> (Accessed 12 Jun 2023)

When estimating the annual generation for a solar PV system, the impact of shading at the site needs to be considered. However, shading is the hardest factor to accurately take into account. There are MCS methods for dealing with shading⁷, but installers do not always correctly account for its impact.

There is greater solar generation for the months from April to September, with a significant decrease in generation between November and January (see figure 1.6).

Estimates of solar PV generation provide a good benchmark to compare system performance. However, the annual solar irradiance can vary around 5% per year, sometimes with considerable variation in monthly generation due to variations in weather conditions.

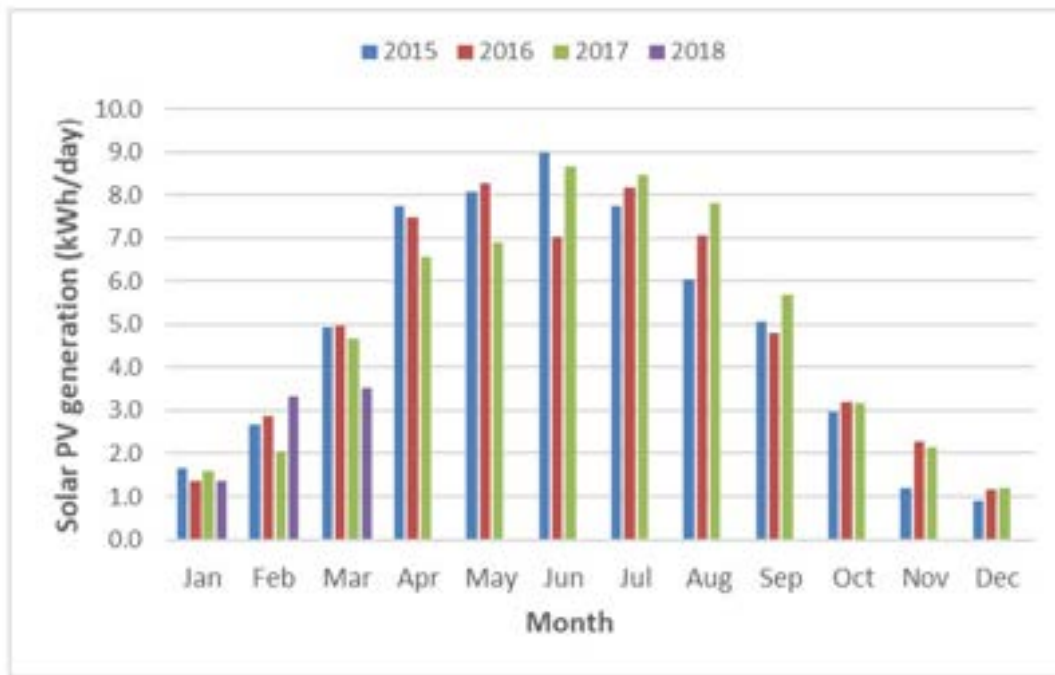

Figure 1.6 Variation in solar PV generation between 2015 and 2018 for a 2.35kW solar PV system in London orientated 60 degrees from south

⁷ MCS Guidance Document MGD 005 (2020), Solar PV Shade Evaluation Procedure: A method to determine Shade Factor, <https://mcscertified.com/wp-content/uploads/2021/10/MGD-005-Solar-PV-Shade-Analysis-V1.0.pdf> (Accessed 12 Jun 2023)



Action for Warm Homes

2. Installation programme

2.1. Recruitment of households for installations

Recruitment for the Wakefield Mega Solar project began in June 2021 when the Council sent letters to households living in EPC band E, F and G properties (see Appendix 1). The letter informed them about the Mega Solar scheme which was offering free solar PV systems to qualifying properties across Wakefield District. To qualify households needed to meet all the below criteria:

- You are a homeowner (owner-occupier) living in the Wakefield district
- Your total annual household income is £30,000 GROSS or less (including all benefits)
- You live in a domestic house or bungalow with its own pitched roof and loft access.
- Your home has a poor energy efficiency rating (Band D-G), shown via a valid Energy Performance Certificate (EPC)
- You will need to have cavity wall and loft insulation (where applicable), but where this is not installed, help may be available.

The letter included a questionnaire which helped identify whether the property was likely to have a poor energy efficiency rating.

Properties in EPC band D were initially put on a waiting list. This was to assist in limiting the number of properties receiving installations in EPC band D to less than 50% of the total.

The project was also promoted on social media and the Council's website.

2.2. Recruitment of households for evaluation

Wakefield Council wanted an evaluation of the Mega Solar project, which would verify the benefits provided to households from the solar PV installations. The Innovation and Technical Evaluation team at NEA was asked to undertake this task.

Households that were selected to receive solar PV installations with the Mega Solar project were provided with an information sheet about the evaluation (see Appendix 2). Households taking part in the evaluation would receive a more expensive Lux Power hybrid inverter which was able to measure the solar PV generation, solar PV export and electricity import from the grid, as well as provide valuable data to the evaluation team at NEA. The hybrid inverter also allowed battery storage to be installed more easily and 4 of the monitored households subsequently funded installation of battery storage systems.

Households provided permission to obtain electricity meter readings from their energy supplier and were to be invited to take part in an online questionnaire at the end of the project.

The original target number of households for the evaluation was 50. In the end only 28 were recruited as not all those who were willing to take part had installations considered suitable to have a Lux Power hybrid inverter fitted.



2.3. Installations

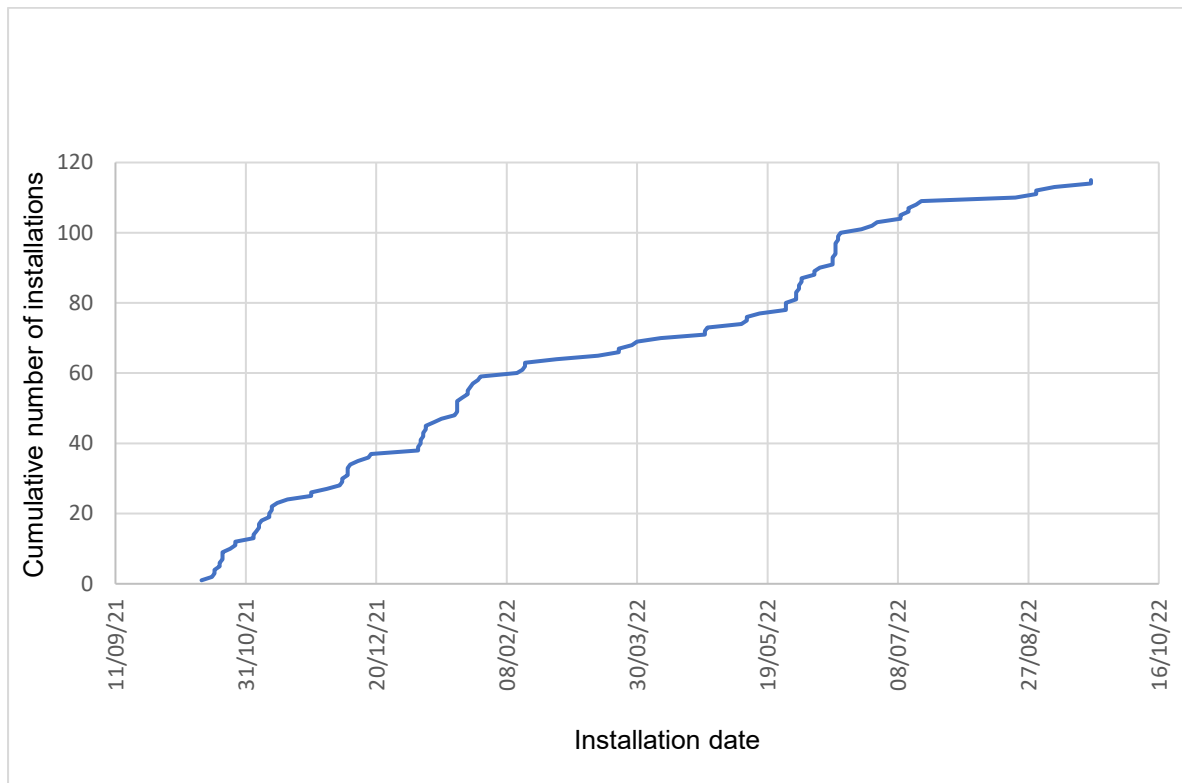

Figure 2.1 Cumulative number of installations on the Wakefield Mega Solar programme

Installations for the Wakefield Mega Solar programme were carried out by ASK Renewables who were based in Barnsley. There was a total of 115 installations which took place between 14 Oct 21 and 20 Sep 22. Figure 2.1 shows how the cumulative number of installations increased over the period of the project.

28 of the solar PV installations (24.3%) had LuxPower LXP3600 hybrid inverters which provided monitoring of the solar PV generation, PV export and household consumption. A data sheet for the LuxPower hybrid inverter is provided in Appendix 3. The remaining solar PV installations had standard string inverters from either Solis or SolaX and the model was dependent on the PV system size.

The panels installed were half-cell modules and either manufactured by JA Solar or Longi. The rated power of the panels ranged from 370W to 385W. Out of the 115 installations, 55 had 10 solar panels and 28 had 8 solar panels (see figure 2.2). In the monitored group, there were 17 installations with 10 solar panels and 6 installations with 8 panels.

80% of the installations had between 8 and 10 solar panels. Only 17 of the installations (14.8%) had smaller arrays of between 4 and 6 solar panels.

Figure 2.3 shows the rated power for the solar PV arrays plotted in bands of 0.25kW. There were 52 out of 115 solar PV installations that were sized between 3.75kW and 3.99kW, with 17 of these in the monitored group.

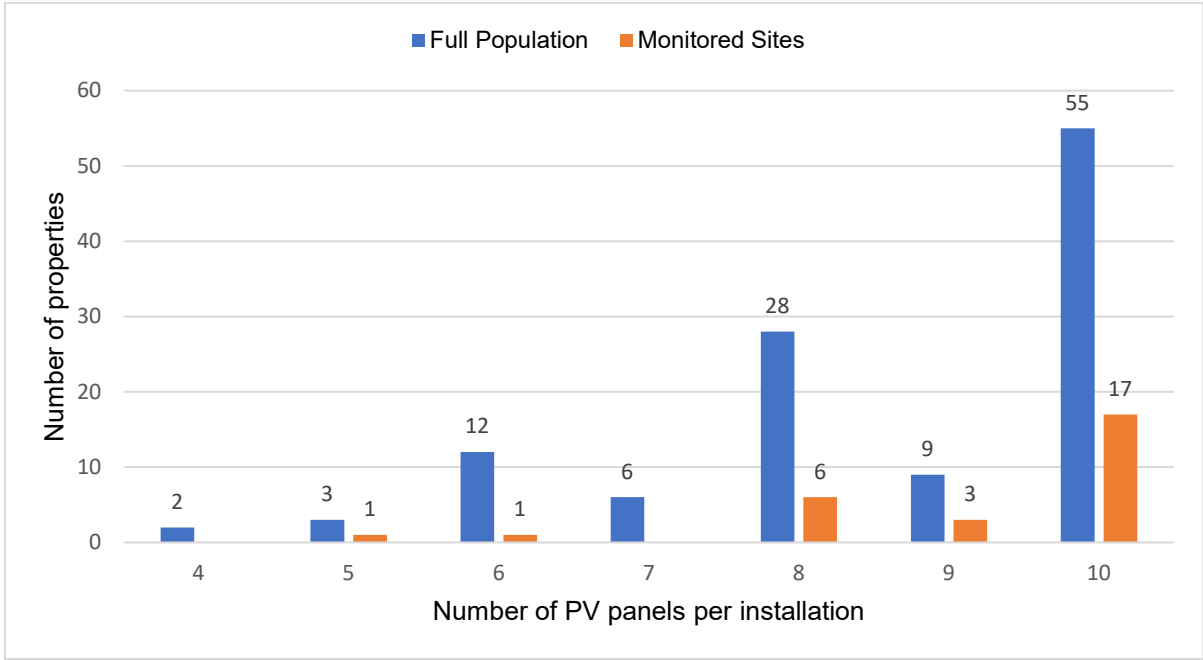

Figure 2.2 Number of solar panels per installation on the Wakefield Mega Solar project

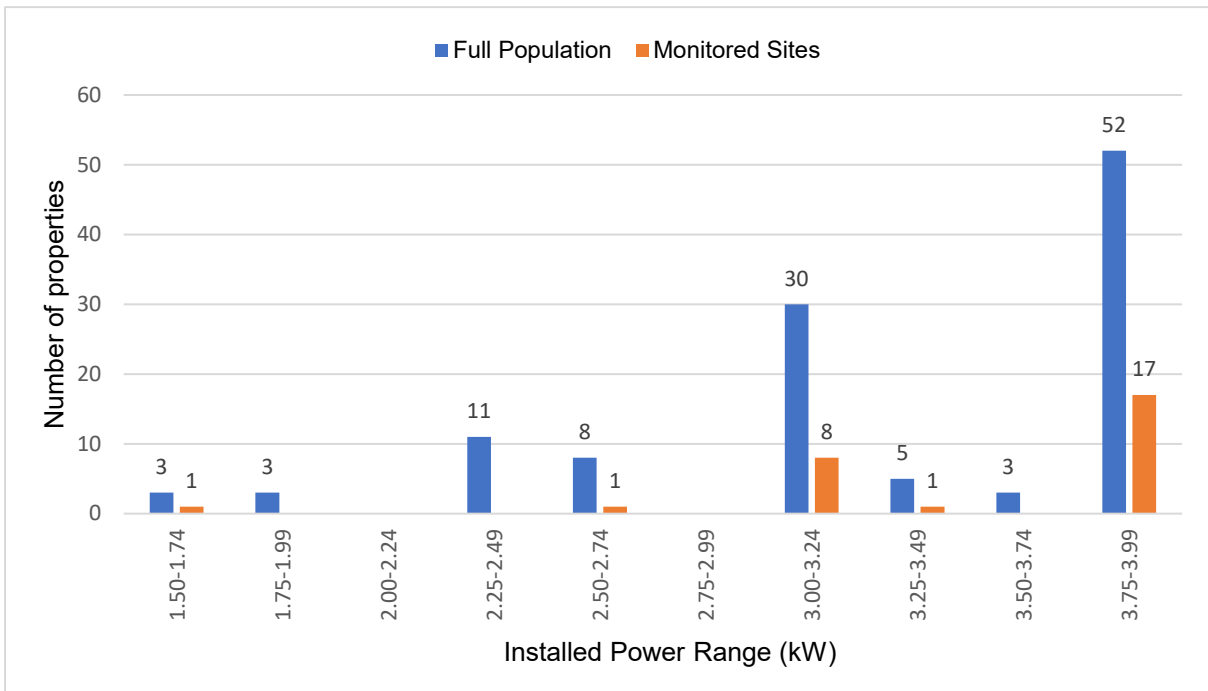

Figure 2.3 Number of solar PV systems installed by range of power output

90 out of the 115 solar PV installations (78.3%) had system sizes between 3.00 and 3.99kW. There were just 25 installations (21.7%) in the range 1.50 to 2.74kW.

Out of the 28 monitored solar PV installations, 26 were between 3.00 and 3.99kW and just 2 installations were in the range 1.50 to 2.74kW.

Figure 2.4 shows that 99 of the 115 installations had a single PV array, while 16 of the solar PV arrays were split across 2 roof faces. Among the monitored sites, 21 had a single PV array and 7 were split across 2 faces of the roof.

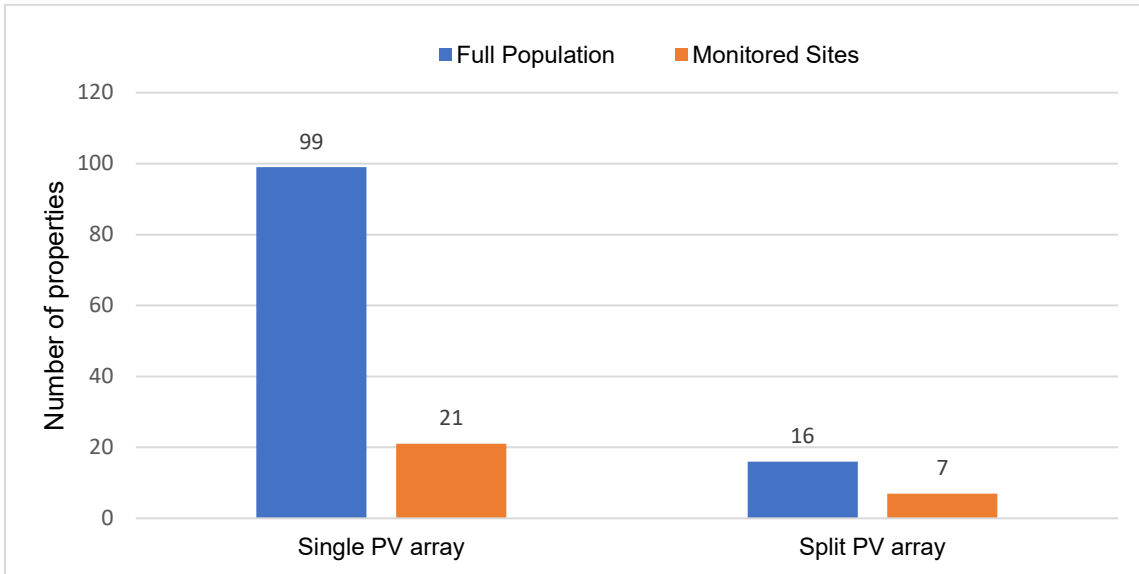

Figure 2.4 Number of properties with single or split solar PV arrays

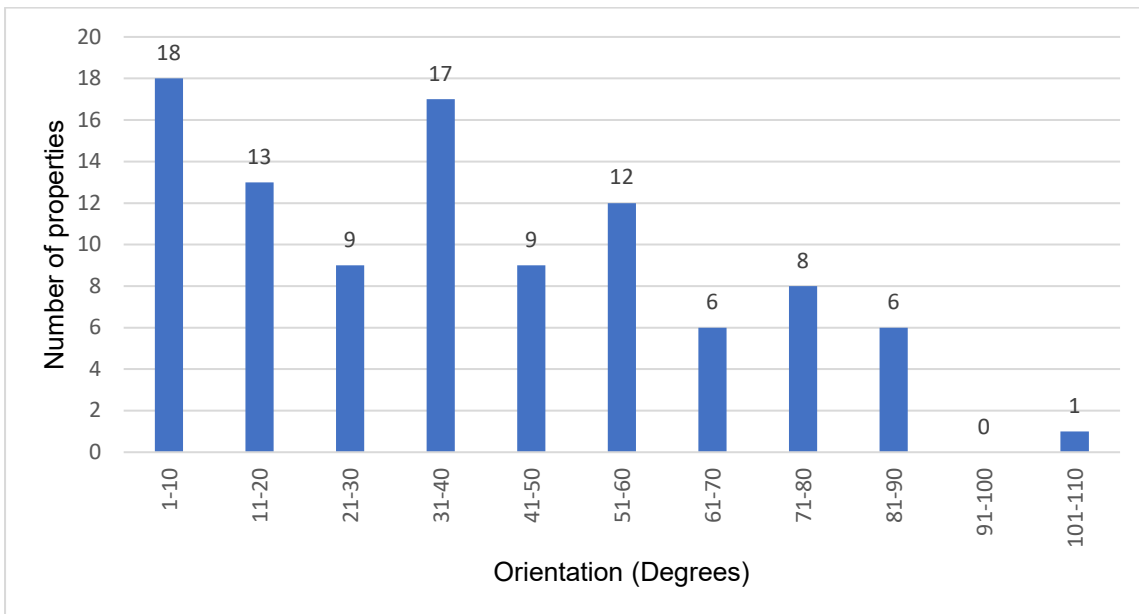

Figure 2.5 Variation in the orientation of the single solar PV array amongst installations

Figure 2.5 shows the variation in the orientation of the PV panels for the installations which had a single PV array. The orientation is shown in bands of 10 degrees. There were 18 properties which were orientated between 1 and 10 degrees away from south. A further 17 installations were in the range 31 to 40 degrees from south. Split solar PV arrays were more likely to be installed on approximately east-west facing roofs.

Annual solar generation depends on factors such as the solar PV system size, the orientation and inclination of the solar PV array, the level of shading on the panels and the location in the country. Figure 2.6 shows estimates of the annual solar generation (by the installer) for the 115 properties which received installations in the Wakefield Mega Solar programme. Out of the 115 installations, 68 (59.1%) had an estimated annual generation of between 2,500 and 3,500 kWh. There were also 23 installations (20%) with an estimated annual generation of between 1,000 and 2,000 kWh.



Action for Warm Homes

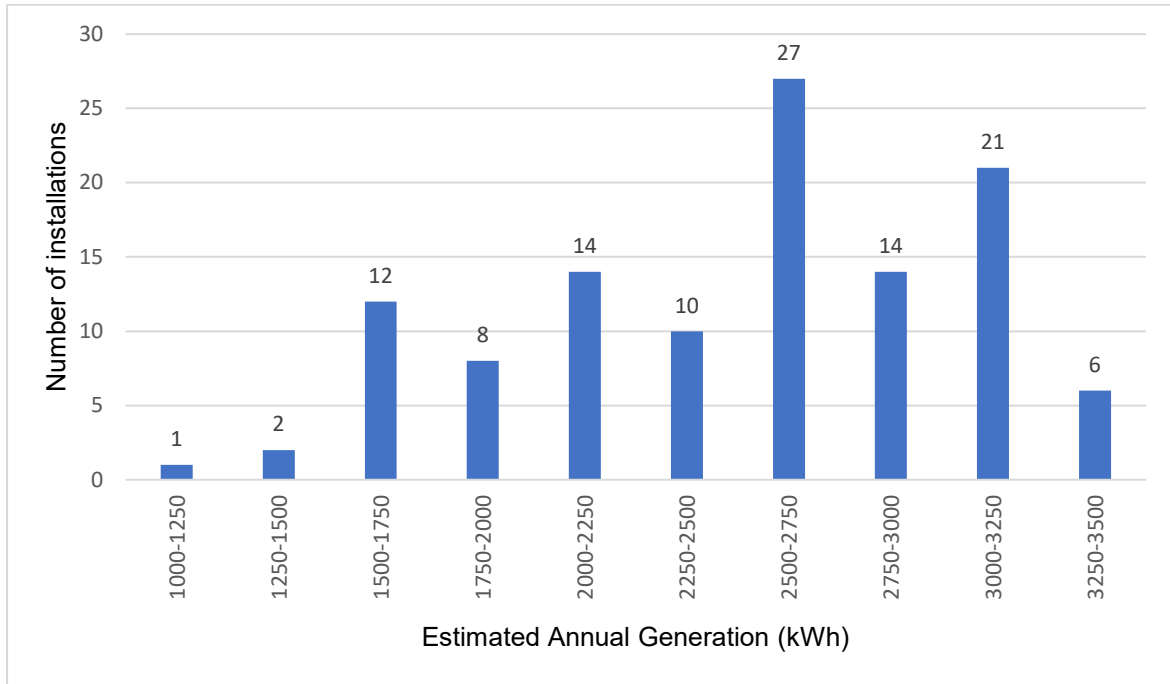

Figure 2.6 Estimated annual solar PV generation for the properties which received installations



2.4. Characteristics of the monitored sites

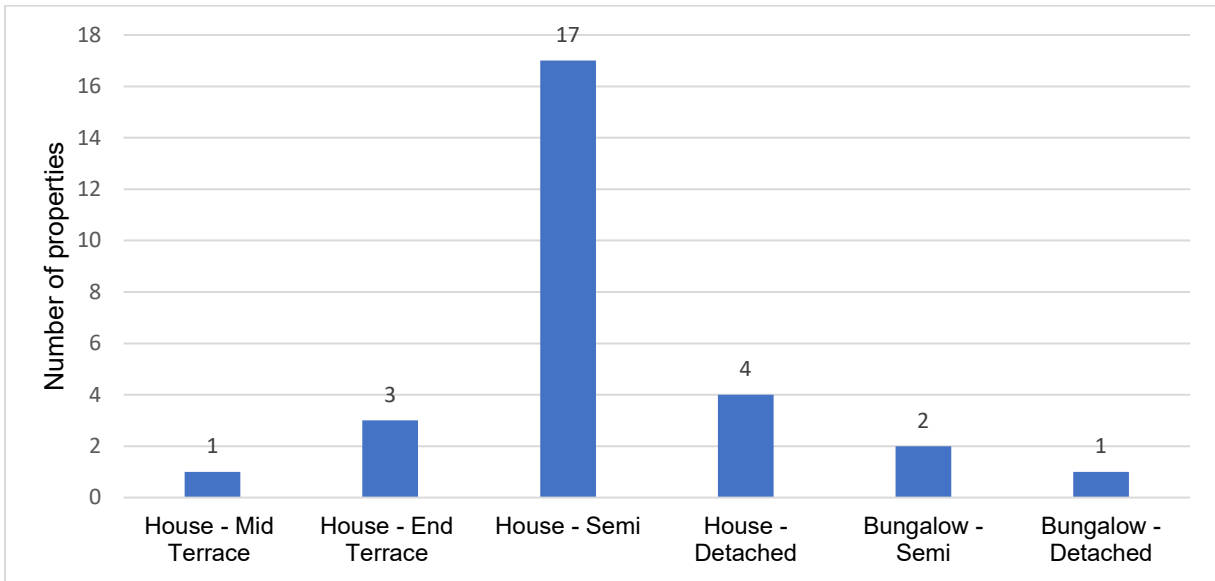

Figure 2.6 Dwelling types of the monitored sites for the Wakefield Mega Solar project

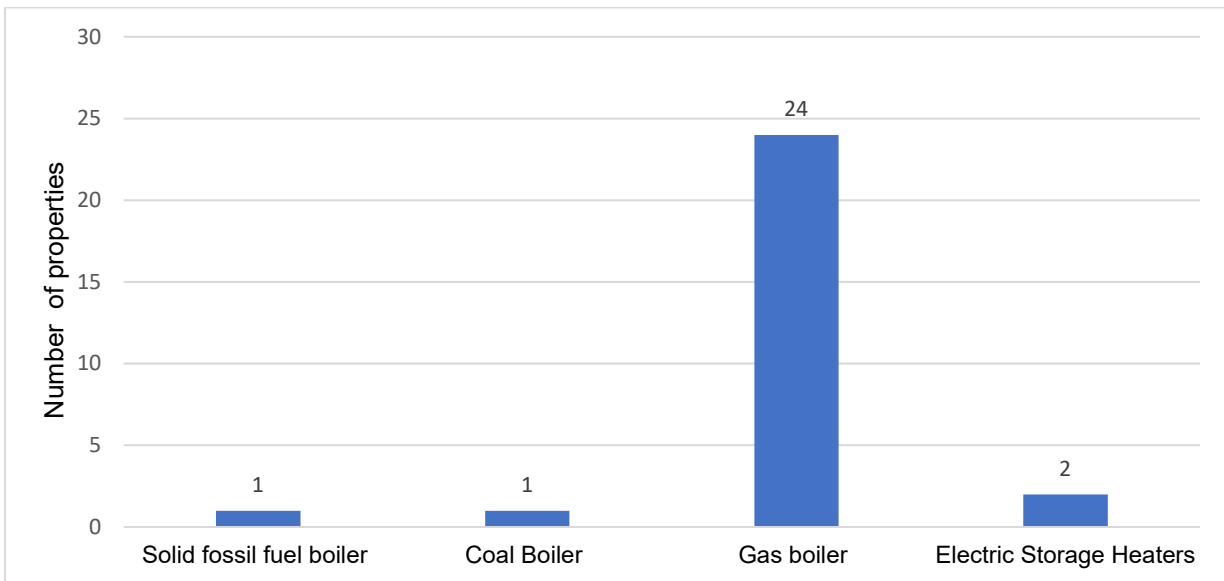

Figure 2.7 Method of space heating for the monitored sites for the Wakefield Mega Solar project

There were 28 properties in the monitored group for the evaluation of the Wakefield Mega Solar project. 17 of these properties were semi-detached houses, 4 were detached houses and 4 were terraced houses (mid or end). There were also 3 bungalows, with 2 of these being semi-detached.

Space heating was provided by a gas boiler for 24 out of the 28 properties. Among the rest, 2 used storage heaters and there was a property with a coal boiler and another classed as having a solid fossil fuel boiler.

Figure 2.8 shows a plot of the cumulative number of properties against floor area. Among the monitored sites, the floor area ranged from 67m² up to 168m².

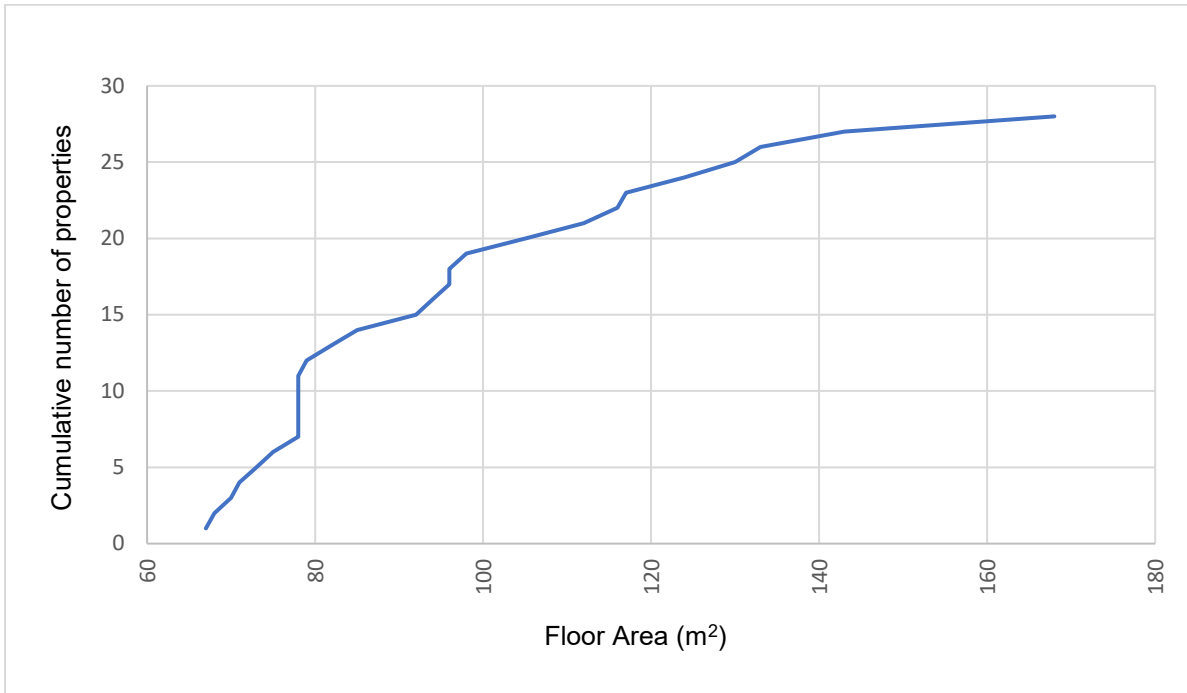

Figure 2.8 Plot of cumulative number of properties against floor area

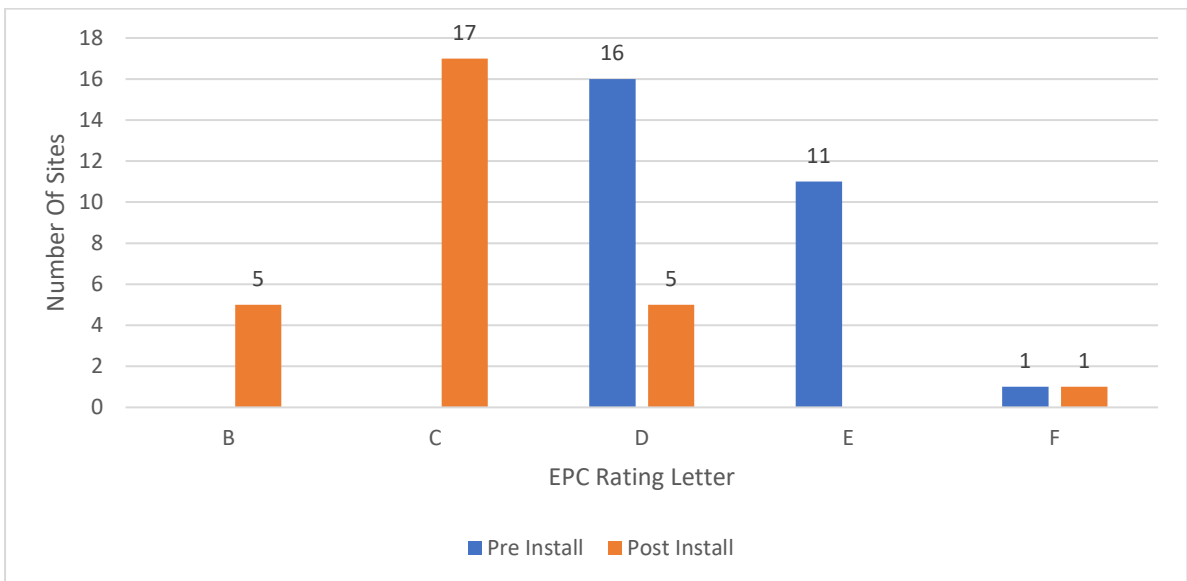

Figure 2.9 Energy Performance Certificate band pre and post installation on the monitored sites

The impact of the solar PV installation on the EPC band for the monitored sites is illustrated in figure 2.9. Before the installations, there were 16 properties in band D, 11 properties in band E and a single property in band F. After the installations, 5 of the properties were now in EPC band B, 17 in band C and 5 properties in band D. The property in band F saw an improvement in the EPC score, but not enough to increase the band. This property had the largest floor area and the smallest solar PV array fitted and so there was limited impact.

Among the monitored properties, the EPC score rose from an average of 56.4 to 72.2 after the solar PV systems were installed.

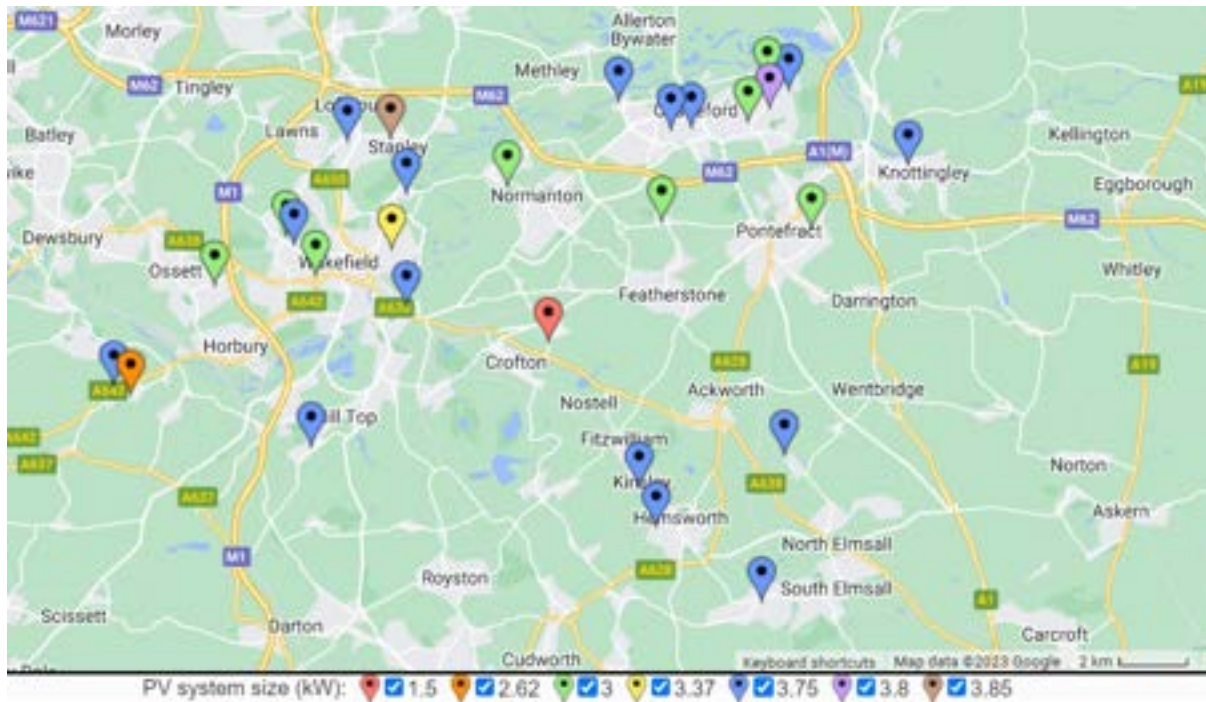

Figure 2.10 Map showing the location of the monitored sites across Wakefield District

Figure 2.10 shows the locations of the monitored sites across Wakefield district along with the PV system size. There were 15 installations which had 3.75kW arrays and 8 which had 3.0kW solar PV arrays. There were 2 large installations that were 3.8 or 3.85kW and a single small 1.5kW installation.

2.5. Characteristics of the monitored households and satisfaction with the installation

Out of the 28 households in the monitored group, 24 completed an online questionnaire. Topics covered included characteristics of the households, their behaviour, their satisfaction with the solar PV installation and perception of the benefits provided.

The residents were asked to rate the installation of their solar PV system. 19 of the households thought it was 'very good', 4 considered it 'good' and a single household thought it was 'average'. The issues noted by the household giving the worst rating were that during the installation, they initially fitted the wrong inverter which needed to be changed. Also, the scaffolding was left in place for several weeks and they had to ask for it to be taken down. Overall, however, this household was very pleased with the system.

Households were also asked how useful the guidance materials were and the explanation of the solar PV system. In this case, 18 of them thought it was 'very good', with 3 considering them 'good' and the remaining 3 noting that they considered them 'average'.

They were also asked whether they were happy with the solar PV system and if they would recommend a similar installation to their friends. Out of the 24 households who completed the questionnaire, 23 said 'yes' for both questions and a single household said 'no'.

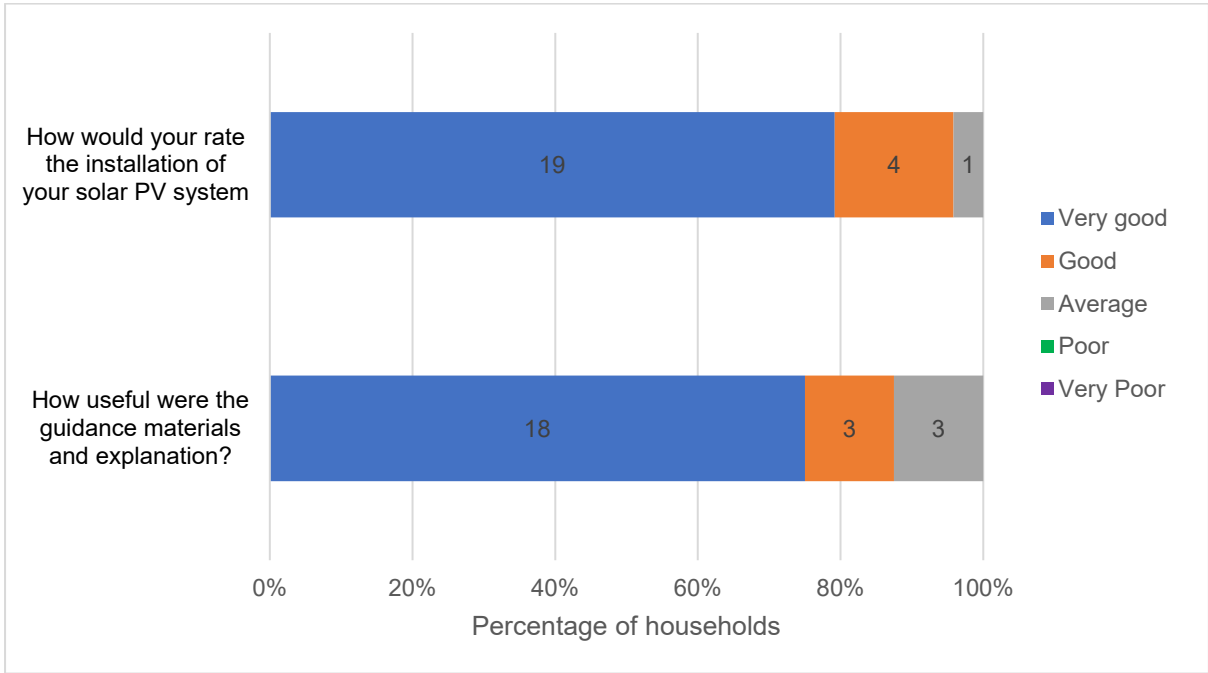

Figure 2.11 Rating the solar PV installation and usefulness of the guidance materials

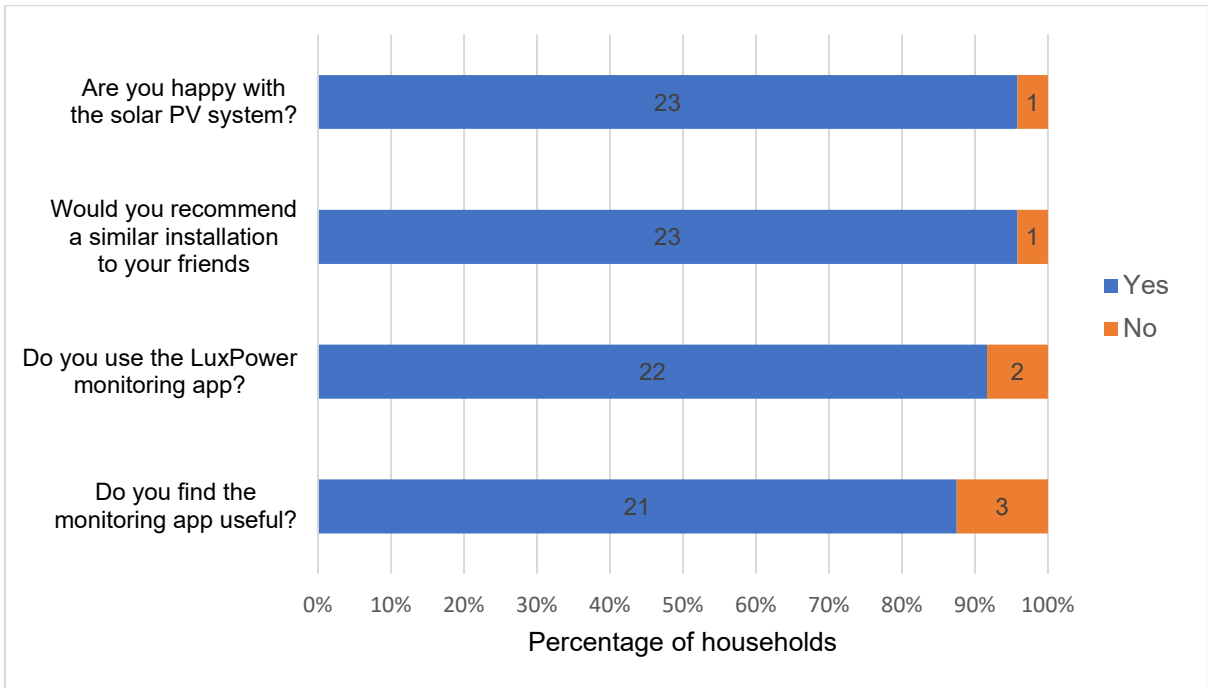

Figure 2.12 Satisfaction with the solar PV system and usefulness of the monitoring app

The unhappy household had expected their electricity bills to reduce considerably, and they had not. They also had technical problems using the LuxPower monitoring app which meant they could not see any savings. The system was offline all the time despite having a new Wi-Fi dongle fitted. The installers said the issue was due to the customer having a complex Wi-Fi system using repeaters around the house which caused problems with connectivity.



There were 22 households who were using the LuxPower monitoring app to be able to see the generation from their solar panels and their electricity consumption. The 2 households who were not using the app were the unhappy household who had technical issues with the app and another household where the resident felt it was too complex to engage with at their age.

The LuxPower monitoring app was found to be useful by 21 of the 24 households who completed the questionnaire. They also described how they were using the monitoring app.

- Use it every day and put appliances on at generation times
- Like to see when the best time to use appliances when system is at its optimum
- I can see what we are generating on the app and use our electricity accordingly like charging devices up, washing machines on etc
- I check the app seeing solar production, consumption and export to the grid. It is interesting to see and acknowledge
- Of interest to see what the national grid is gaining
- I check how much the solar is producing and use my appliances (dishwasher, washing machine, tumble drier etc) at times when there is enough generation
- Just to monitor usage
- To check how much electricity we are using
- I check the app so I can decide if I am going to use the washing machine
- Check how much electricity is generated during the day
- Look at it to see what is generating and may put on washing if generating enough. Use one thing at a time and decide what to do with the electric based generation
- We use it to save money. i.e. showering when the solar panels are at maximum
- Useful to see what is generated by the panels and going to the grid and being used in the home
- Checking in to monitor my daily usage/output
- It is useful to know how much charge the solar is generating
- Use to see when there was higher generation and could then use appliances. Monitor generation and consumption
- By monitoring the app, I can see when it is best to use some of my high energy use items
- To know when to use appliances
- If it is generating a lot will use washing machine and dishwasher. Like to see generation and consumption per day
- Had a battery installed. It is a good way to see how the battery is charging. Useful to know on a cloudy day is generating

Among those not using the monitoring, the comments were:

- Is offline all of the time despite new dongle installed a few months after panels installed, so unable to monitor
- Not using it
- Don't use the app, only just got a mobile phone. Use smart meter in-home display

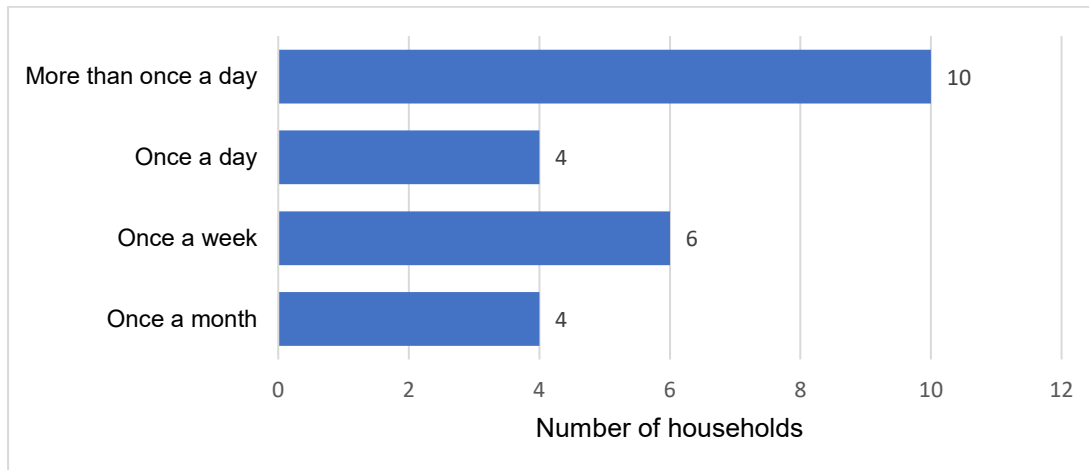

Figure 2.13 Frequency households were using the LuxPower monitoring app

The households were asked how frequently they were using the LuxPower monitoring app. 10 of the 24 households that responded said they were using more than once a day with a further 4 households using it once a day. There were 6 households that used the app once a week and 4 households that responded once a month. The households with a monthly use included the 3 households who said they did not find the monitoring app useful.

Households were also asked to describe any problems they had with the monitoring app. The problems noted included:

- Was a pain to reset when I changed broadband supplier
- I upgraded the Wi-Fi and the app no longer connected. I watched a YouTube video which showed me how to connect it
- Not really; occasionally readings are unavailable due to a technical error
- Only because our internet was rubbish
- App needs to be restarted to show the correct data
- Had some issues around updates to the app
- As noted before, not online so unable to read app even after new dongle installed
- Not using monitoring, at my age it is a bit much to manage
- Lost the login
- Occasionally it says network not available. Had to restart broadband router or phone

The main issue households faced was the Wi-Fi dongle on the inverter losing connection with the internet. This typically occurred if the residents changed broadband supplier or updated their broadband router, with a change in the Wi-Fi signal and password. This issue led to gaps in the monitoring data for about 8 households and affected the NEA performance analysis.

Residents were also asked if there had been any reliability issues with the solar PV system. Out of the 24 households, 19 commented that there had been no reliability issues or they had not been aware of any. The household who was generally unhappy with the installation noted that in Autumn and Winter the panels were unreliable (most likely had low generation) with very little savings. This was a 3kW installation with panels on roofs at 40 and 130 degrees from south. Without the monitoring, the resident might not have been aware of the performance. Also, they may not have realised how much the generation reduces in Autumn and Winter.



A couple households discussed the impact of power cuts. One of these said that the system cut out and needed a switch turning back on. Another household noted there was an issue after their smart meter was fitted. For several households, the smart meter was fitted and the engineer subsequently fitted the CT-clamp for the inverter back on the meter tail in the wrong orientation or on the wrong cable. This led to incorrect readings with the monitoring system.

A household noted that there were issues with the monitoring system where the household consumption was following the solar generation. This issue had been noticed by NEA with the monitoring for a couple households and was likely to be due to issues with the CT clamp or cable. The installer noted that there had been a kink in the CAT5 cable at one site which led to incorrect readings and replaced the cable.

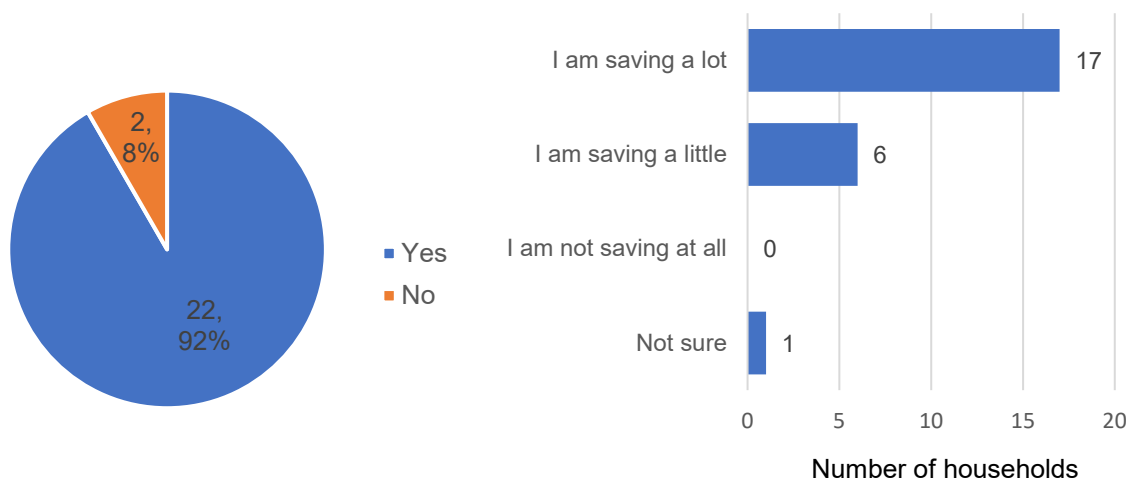

Figure 2.14 (a) Are you making savings? (b) Perception of level of savings

Out of the 24 households who completed the questionnaire, 22 thought they were making savings on their electricity bills as a result of the solar PV system with 2 households responding they were not. Out of these 2 households who noted they thought they were not making savings, 1 of these had generally been unhappy and their monitoring system had been offline for about a year. The response from the other household was probably a mistake as elsewhere they felt they were saving a lot. When asked about their perception of the level of the savings, 17 of the households thought they were saving a lot, 6 households felt they were saving a little and there was a single household that was not sure.

The households were asked the amount of time there was a resident typically at home during the day. The options were 'Home all day', 'In half the day' and 'Out all day'. These along with the annual solar generation and household grid consumption can be used to estimate the percentage of self-consumption of the solar generation. MCS has published a guidance document with tables which allow an estimate to be made⁸.

⁸ Solar PV Self-Consumption – A method to determine the Electrical Self-Consumption of Domestic Solar PV Installations with and without Storage, MCS Guidance Document MGD 003 Issue 2.0, MCS (2022), <https://mcs-certified.com/wp-content/uploads/2022/04/MGD-003-Solar-PV-Self-Consumption-Issue-2.0-Final.pdf> (Accessed 28 Jun 23)

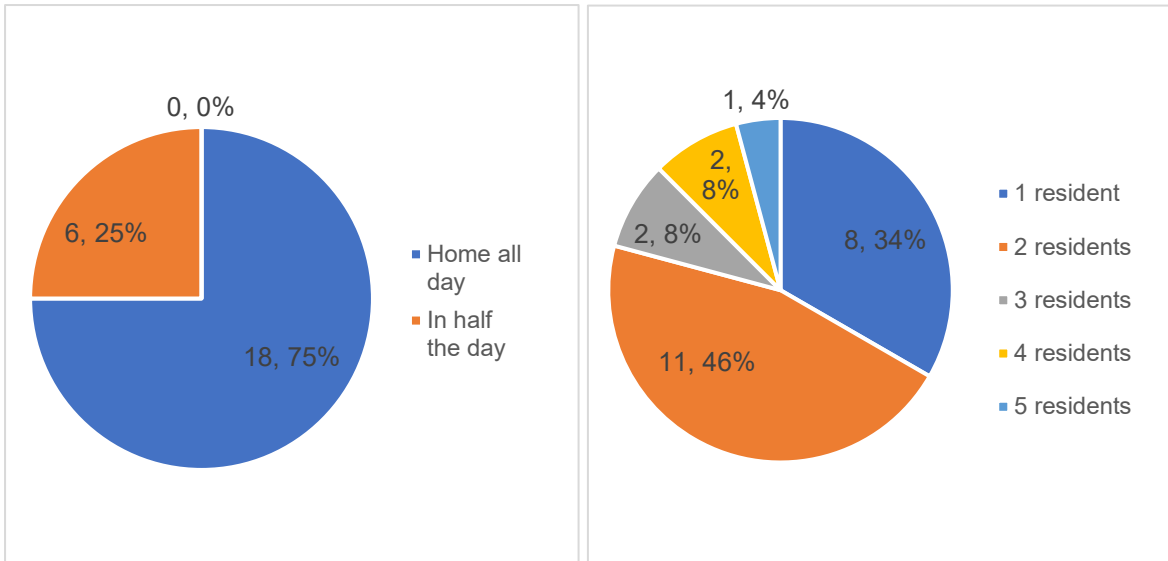

Figure 2.15 (a) Amount of time at home (b) Number of residents

There were 18 of the 24 households who were home all day with the remaining 6 in half the day. None of the households were out all day as a family might be who were all working full-time. Another factor which might affect the household electricity consumption was the number of residents. There were 8 households with a single resident and 11 with 2 residents. There were 2 households each which had 3 and 4 residents and a single household with 5 residents.

The households were asked whether they were more aware of how they used electricity since having the solar PV installation. Out of the 24 households 23 agreed they were more aware. They were also asked if they had changed the way they used electricity since the installation of the solar PV system. In this case 21 households said they had changed their behaviour while 3 households had not.

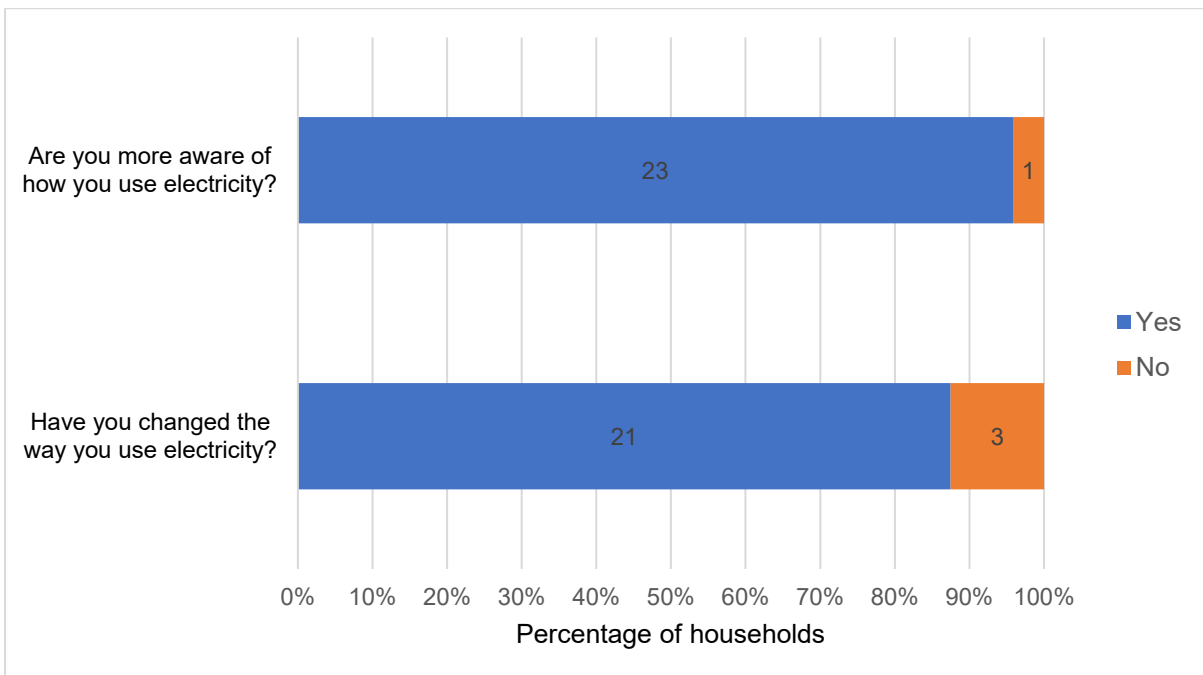

Figure 2.16 Change in awareness and use of electricity

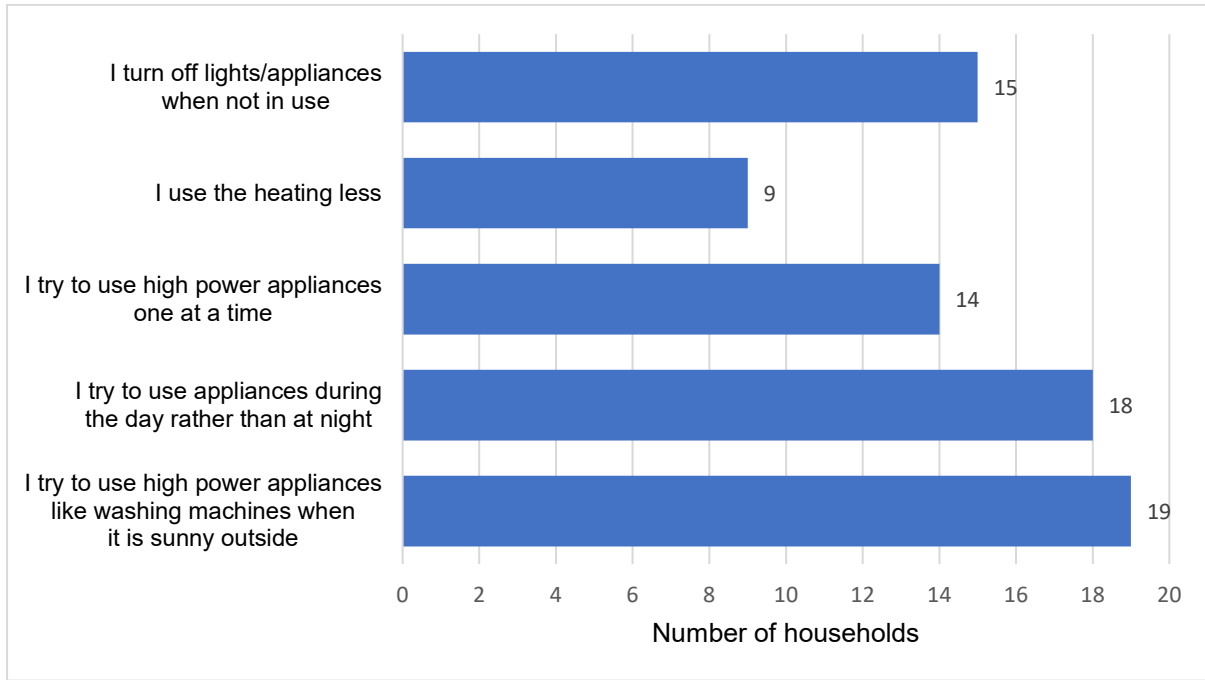

Figure 2.17 Ways in which households changed their behaviour

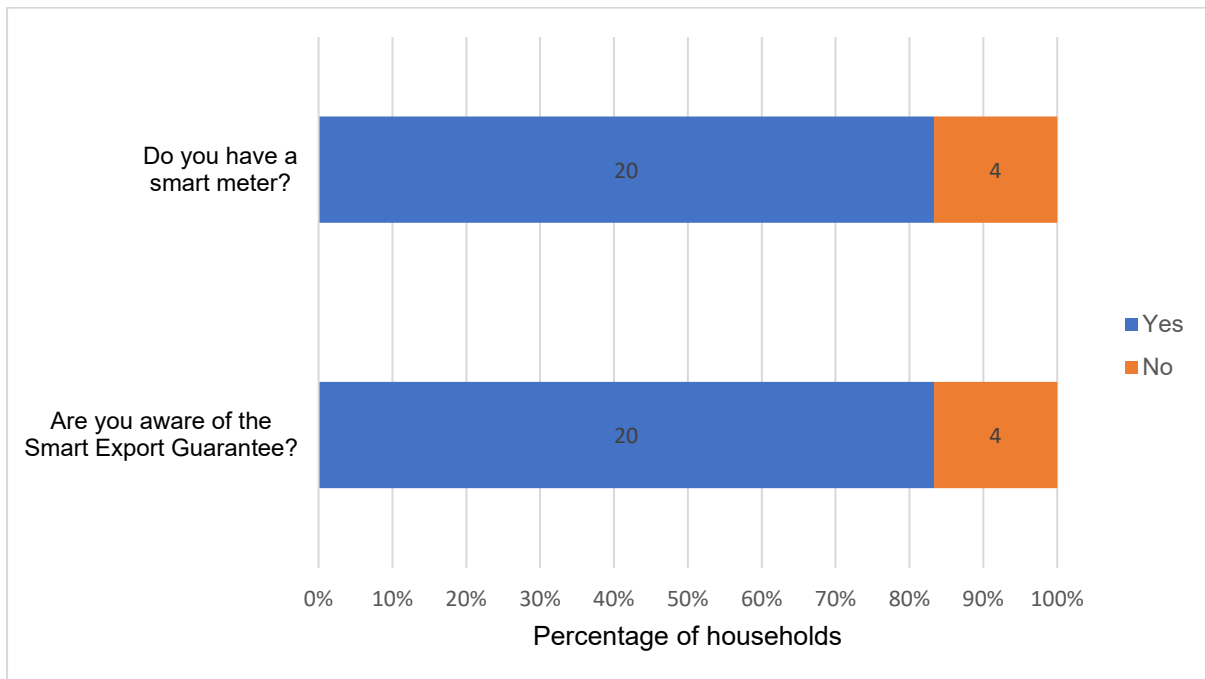

Figure 2.18 Smart meters and awareness of the Smart Export Guarantee

The households were also asked to describe the way they had changed how they used electricity. Figure 2.17 showed 15 of the households were turning off/appliances when not in use and 9 were using the heating less. These were examples of general methods for energy saving. There were 14 households who tried to use high power appliances one at a time. This would mean more of the power was likely to come from the solar panels. 18 of the households tried to use appliances during the day (when the solar panels would be generating) rather than at night. 19 of the households said they tried to use high power appliances like washing machines when it was sunny outside. This would be when there was greater generation from



the solar panels and it was more likely to washing machine could be powered for free. The last 3 examples show that most of the households were changing how they used appliances in order to maximise their savings from the solar PV.

20 of the 24 households had smart meters. Households with solar PV can be paid by their energy supplier for electricity which is exported to the grid through a scheme called the Smart Export Guarantee (SEG). Each supplier's application process is different and the rates paid for the SEG vary between suppliers and must be greater than zero. Households must have a meter capable of providing half-hour export readings (which a smart electricity meter can do). Again, 20 of the 24 households were aware of the Smart Export Guarantee.

Households have typically had mixed experiences in claiming the Smart Export Guarantee from electricity suppliers. The questionnaire asked the households in the monitored group about their experience of the Smart Export Guarantee, if they were aware of it and whether they had managed to sign up to it. Comments from the households who were aware are below:

- Great experience, straightforward
- I am aware of the scheme and it would be of interest
- The energy companies should reward their exporters more for producing electricity for them
- Not signed up
- Should pay a similar amount as the price you pay to import
- Haven't signed up for it. Not worth it at 3p/kWh. Not worth the trouble for applying for £70 per year
- With E.ON once a year in June
- Took ages to set up!
- Filled in the application form, but it took a year to sort out
- Not sure
- Currently with Octopus Energy which are part of the scheme, been really helpful during the process
- We have an export tariff
- Have struggled to sign up to it as British Gas kept asking for additional information
- Not signed up to it
- Haven't signed up to it. The electricity company I am with pay 1.5p/kWh, so it wasn't worth it
- The company I contacted said they weren't participating at that time
- Signed to Shell Energy in May 2022 at 3.6p/kWh and paid £50 after a year. Took a long time to respond
- Signed to Octopus despite not being a customer. That meant it was a bit harder to sort out
- Very difficult to sort out

The final question was an opportunity for households to say what they thought about the project, was it beneficial, what went well, what went less well and whether they were pleased with their solar PV system. Responses to this question are provided in table 2.19.



Comments from households about the project

It was quite laborious at first as it seemed I had about 3 visits and forms to fill in to get started. Too many hoops to go through and at one point I nearly gave up because of the slow progress. Far too much red tape. I also wish I had taken the opportunity to purchase a storage battery. I was quoted £1500 at the time, and they are now they are nearer £4500 since everyone is looking to make savings.

Yes, I'm pleased.

Everything from start to finish was 100% fantastic! From the local authority to the company that fitted them who I must say went above and beyond absolutely brilliant!! The men that fitted them were also amazing what more can I say!

Yes, really pleased thank you so much, really grateful.

I am pleased with the panels. However, I am finding it difficult to calculate what, if any, benefit I have received. BG moved my account from an old to a new system - very confusing bills due me to submitting actual reading and BG using estimates!

Excellent project. I know people who wished they had taken up the offer but wrongly thought they wouldn't be eligible. Definitely beneficial to me. I am at home during the day and can take advantage of the solar produced during the day. I have sent quite a lot back to the grid so it would be more beneficial if I had a battery storage system as well but the cost is prohibitive to me at the moment.

Beneficial to me regarding savings and very happy overall

Free electricity in summer not so good in winter months

Thank you, I just like to say we almost did not sign up, as the leaflet Wakefield sent looked fake printed on very cheap looking paper, I wish more people were aware, my cousin who lives in the same area was not made aware so missed out.

Was beneficial, installers cracked a roof tile but that is the only issue I had.

I think the programme should be rolled out countrywide and Government should get the treasury to help people with it. We are more than happy with the installation and we have made massive savings. When the annual bills went up, our Direct Debit for electricity only increased by £2/month compared to before.

Pleased over all.

The communication between the council/installers and us was excellent, we are very grateful to have been accepted for the project, however we have found very little benefit money wise, bearing in mind energy bills have increased massively due to political reasons, basically when the sun does not shine, the panels are not effective, and battery storage is not possible due to cost.

There are no problems with the panels. The only problem has been claiming the export tariff with delays of over a year.



| |
|--|
| <p>Was a bit apprehensive before about how they were fastened to the slate roof. When the installation team showed how they did I was quite pleased. I am quite happy with the installation and think I am making good savings.</p> |
| <p>Very pleased with my PV system, had no issues and would highly recommend it to everyone. Friends and family have been jealous throughout the whole journey.</p> |
| <p>It has been a very positive experience and we work with the solar to make the most of it.</p> |
| <p>Don't have any complaints. The only issue has been the difficulty of signing up for the smart export guarantee. Everything else has been spot on and I am making savings.</p> |
| <p>I'm very pleased with the project, its saved me quite a lot of money over the last couple of years and the signing up process was so straight forward and so was the installation.</p> |
| <p>From application to having the panels fitted went like a dream. The lady from the council was fantastic. Everything from start to finish was positive. I cannot praise them enough. It has been a really, really positive experience.</p> |
| <p>I am really happy with panels only sorry my family and friends didn't get the opportunity too.</p> |
| <p>During the installation, they initially put in the wrong inverter which needed to be changed. The council staff were very helpful and the installer was also very good responding to telephone calls. The scaffolding was left in place for several weeks and I had to ask for it to be taken down. Overall, I am very pleased with the system.</p> |
| <p>I rate it 100% and everyone should get solar panels. You have to be wise to how the system works and use appliances based on the weather and not put all appliances on all at once.</p> |
| <p>It is a good project.</p> |

Table 2.19 Comments from households about the project

Out of the 24 households only a single household did not make some positive comment about the project. There were 17 households that only made positive comments about the project. The issues that households commented on were:

- The scheme required too many visits and forms to complete
 - Note that some additional forms were required for the project evaluation
- Installation issues
 - Household with a cracked tile
 - Household had the wrong inverter fitted and the scaffolding left up for too long
- Savings not as high as expected
 - The monitoring system was not working for a household
 - Another had confusing bills with the supplier using estimates
- Difficulty and delays with the sign up for the Smart Export Guarantee

3. Monitoring of installations

3.1. LuxPower LXP hybrid inverter



Hybrid Inverter LXP3-6K

Figure 3.1 LuxPower LXP3600 hybrid inverter

The 28 households who agreed to take part in the evaluation of the project had a more expensive LuxPower hybrid inverter (with a data sheet in Appendix 3). This was able to monitor the export to grid and grid consumption in addition to the solar PV generation as for a standard string inverter. The grid import/export was measured with a current transformer (CT clamp) which was fitted around the live cable of the household electricity supply. It was important that this CT clamp was fitted in the correct orientation so that the grid import/export was recorded correctly.

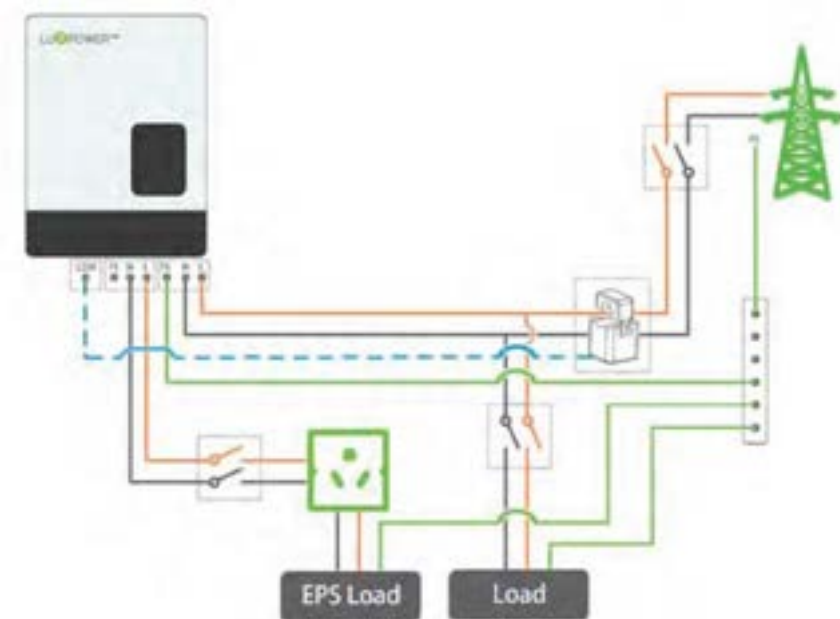

Figure 3.2 Wiring diagram for the LuxPower LXP3600 hybrid inverter with a CT clamp⁹

⁹ LuxPower LXP hybrid inverter user manual, <https://luxpowertek.com/wp-content/uploads/2022/02/Hybrid-3-6K-UM-2.0-04.pdf> (Accessed 12 Jun 2023)



Action for Warm Homes

A Wi-Fi dongle was fitted in the wireless communication module connection at the base of the hybrid inverter and the system was connected to the internet via the household broadband. A video showing how to connect the Wi-Fi dongle to the household Wi-Fi has been published by Infinity Innovations¹⁰.

Installing a hybrid inverter also meant it was easier for households to add battery storage to the solar PV system. Over the duration of the project, 4 of the 28 households installed their own battery systems to improve their savings from the solar PV system.

¹⁰ Lux Power connecting the WiFi dongle, Infinity Innovations, <https://youtu.be/Mm6Dtpfp8GU> (Accessed 12 Jun 2023)

3.2. LuxPower monitoring



Figure 3.3 (a) Overview screen
Screenshots from the LuxPower View app

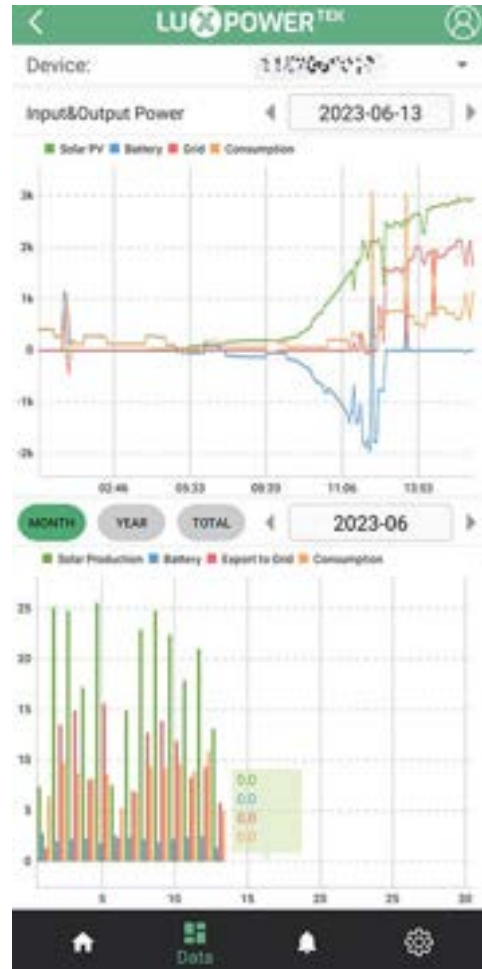

Figure 3.3 (b) Data screen

The households with the LuxPower hybrid inverter were able to view the generation and consumption data via the LuxPower View app. This had an Overview screen which showed the values for today and since installation for solar yield (generation), battery charge, feed-in energy (export to the grid) and household consumption. There is also a diagram which shows the current values of generation from the solar panels, import or export to the grid and household consumption.

The data screen includes a graph of input & output power. It is possible to plot this graph for any day to see the solar generation and household consumption on that day. On the lower half of that screen is the energy overview bar chart. This shows the solar production, export to grid and consumption for each day in a month or each month in a year.

The project team monitored the systems via the LuxPower Monitor Centre. This web portal provided monitoring of all 28 installations with a single login. This would typically be used by installers or owners with multiples systems like a social landlord. It provides similar data to the LuxPower View app along with more advanced features which are useful for installers in diagnosing faults.



Figure 3.4 shows an example screenshot from the Monitor section of the LuxPower Monitor Centre portal for a Wakefield Mega Solar installation. The system had generated 20.3kWh by 18:05 on 12 June 2023 and 4,478.6kWh since it had been installed in October 2021. Out of the 4,479kWh which had been generation since installation, 3,406kWh had been exported to the grid. This meant that 1,073kWh of the solar generation had been consumed in the home. This corresponds to a level of self-consumption of about 24%.

The system information diagram shows that string 1 of the solar PV system was generating 719W at the time of the screenshot and string 2 was generating 143W. There was 168W being used in the home and 678W was being exported to the grid.



Figure 3.4 Summary and current system information from Monitor section of LuxPower portal

An Input & Output Power graph is shown in figure 3.5 from 10 June 2023. Solar PV is shown in green while household consumption is in orange. The electricity to and from the grid is shown in red. If it is negative, there is grid import and if it is positive electricity is being exported. There is a baseload electricity consumption of about 100 to 250W overnight and this is imported from the grid (red curve is negative) until nearly 06:00. From this time the solar generation increases and soon the grid curve switches from negative to positive (export).

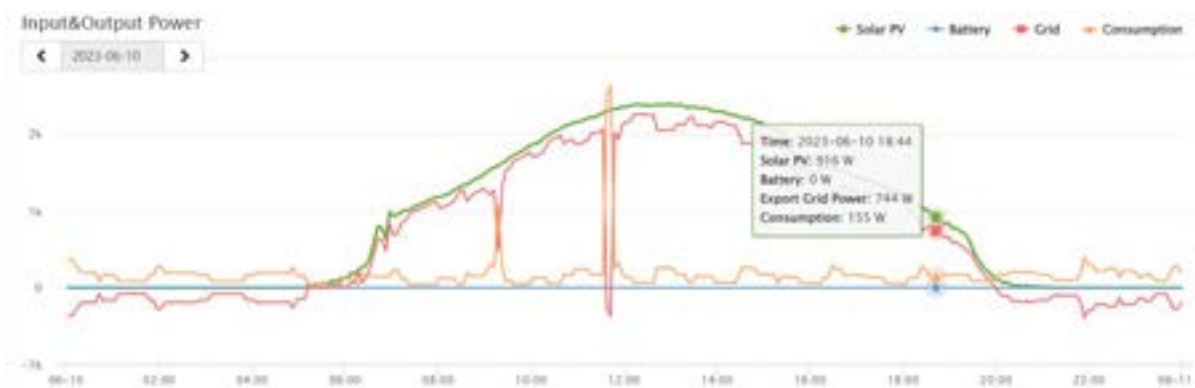

Figure 3.5 Input & Output Power graph for a household on 10 Jun 2023



The grid export is about 100-200W below the PV generation for much of the day until about 20:00, when the solar PV generation becomes negligible, and the household starts to import electricity from the grid again.

There is a peak in consumption at about 09:20, when the household consumption increased to 1,075W and the export decreased to about 500W. At 11:45, there was a larger peak in household consumption of 2,632W. The solar was no longer able to fully power the household consumption and so it was necessary to import 370W from the grid for a short period.



Figure 3.6 Energy Overview graph for a household for 2022

There is also an energy overview graph which plots monthly values of solar production, export to grid and consumption for the household for a particular year. If there is a battery system installed, it also shows the battery charge. If the month option is chosen, the graph will plot daily values for a particular month.

If you hover over a bar on the chart, the graph will display the numerical values. Since data from the charts could not be downloaded, it was necessary to manually collect monthly data in this way from the Energy Overview charts. Gaps in data were also noted using the month option.

The aim of the evaluation was to assess the benefits provided to households receiving the solar PV systems in the Mega Solar programme, with a sample of the households monitored. The LuxPower hybrid inverter was recommended as a good solution for the monitoring. It cost about £200 more than a standard inverter but could provide online monitoring of the solar generation and household consumption. The household also benefited from having access to the monitoring and for it being easier to add a battery storage system.

It had been suggested that the hybrid inverter would be a highly reliable method to collect data and there was little risk of any data loss due to memory in the inverter. In practice, several issues occurred which affected data collection. These included loss of connection to the portal when households changed their broadband router, and issues with data quality due to problems with the CT clamp and cable used by the inverter on the household supply.



3.3. Factors affecting the monitoring

| Issue | Description and mitigation |
|---|---|
| Loss of connection to the internet | <p>In order to transmit data on the solar PV generation, household consumption and export to the grid to the LuxPower portal, the Wi-Fi dongle on the LuxPower hybrid inverter must be connected to the internet. When households switched broadband supplier and had a new broadband router, the Wi-Fi dongle lost connection to the internet and the inverter stopped transmitting data.</p> <p>An engineer visited to reconnect some systems that went offline. Other households were sent a link to a YouTube video explaining how to connect the Wi-Fi dongle to the internet via the LuxPower app. One of the households had a complex Wi-Fi system using repeaters around the house and it proved difficult to get this system back online. Some systems showed large gaps in data as a result.</p> |
| Moving CT clamp | <p>There were households where the CT clamp was moved during electrical work such as fitting a smart meter. The CT clamp was not replaced in the correct orientation and this meant that grid import was recorded as export and vice versa. It was necessary for a visit by the installer to reverse the CT clamp. There was a period of weeks with the installation recording data incorrectly.</p> |
| CT clamp and cable issues | <p>There were installations where the household consumption closely followed the solar PV generation. It was unlikely this was due to appliances used in the home. It was more likely to be due to issues with the CT clamp or cable which meant the grid import/export was not correctly measured. At one site there was a kink in the CAT5 cable for the CT clamp and this was replaced.</p> <p>For another site, data from the monitoring portal was initially as would be expected, but after 26 Apr 22, the household consumption followed the solar generation and there was no export or import from the grid recorded. This was likely to be due to damage or removal of the CT clamp and cable.</p> <p>Another household noted there was a tendency for the household consumption to partially follow the level of solar generation. This was shown by increased household consumption when no appliances were being used. This may also have been due to issues with the CT clamp or cable.</p> |



4. Technical evaluation and results

4.1. Details of monitored properties and their installations

| Ref No | Type of heating | Battery | PV system size (kW) | Install date | Days offline | Issues |
|--------|-----------------|---------|---------------------|--------------|--------------|-----------------------------------|
| WS-01 | Gas | N | 3.00 | 18-Oct-21 | 333 | WiFi dongle and complex WiFi |
| WS-02 | Gas | N | 3.75 | 19-Oct-21 | 183 | Offline from 29 Nov 22 |
| WS-03 | Gas | N | 3.75 | 19-Oct-21 | 0 | |
| WS-04 | Gas | Y | 3.75 | 22-Oct-21 | 0 | |
| WS-05 | Gas | N | 3.00 | 04-Nov-21 | 7 | |
| WS-06 | Storage heater | N | 3.75 | 05-Nov-21 | 0 | CT reversed 5 Jan 22 - 20 Jan 22 |
| WS-07 | Gas | N | 3.75 | 05-Nov-21 | 0 | |
| WS-08 | Gas | N | 3.00 | 06-Nov-21 | 34.7 | CT reversed 23 Nov 21 - 20 Jan 22 |
| WS-09 | Solid fuel | N | 3.75 | 09-Nov-21 | 12 | |
| WS-10 | Storage heater | N | 3.00 | 10-Nov-21 | 0 | No grid recorded after 16 Jun 22 |
| WS-11 | Gas | N | 3.75 | 12-Nov-21 | 34.5 | Loss of AC connection 25 times |
| WS-12 | Gas | N | 3.80 | 25-Nov-21 | 0 | |
| WS-13 | Gas | Y | 3.37 | 17-Dec-21 | 15 | Offline in May 2022 |
| WS-14 | Solid fuel | N | 3.75 | 05-Jan-22 | 17 | Offline 22 May 22 to 7 Jun 22 |
| WS-15 | Gas | N | 3.75 | 05-Jan-22 | 0 | |
| WS-16 | Gas | N | 3.75 | 06-Jan-22 | 40 | Offline from 21 Apr 23 |
| WS-17 | Gas | N | 3.75 | 07-Jan-22 | 8 | Offline 27 Jul 22 to 3 Aug 22 |
| WS-18 | Gas | N | 2.62 | 08-Jan-22 | 0 | |
| WS-19 | Gas | N | 3.00 | 14-Jan-22 | 70 | 3 extended periods offline |
| WS-20 | Gas | N | 3.00 | 20-Jan-22 | 6.8 | Offline in Sept and Oct 2022 |
| WS-21 | Gas | N | 3.75 | 24-Jan-22 | 0 | CT reversed and other issues |
| WS-22 | Gas | N | 3.00 | 25-Jan-22 | 132 | Offline 31 May 22 to 10 Oct 22 |
| WS-23 | Gas | N | 3.75 | 26-Jan-22 | 3 | |
| WS-24 | Gas | N | 3.00 | 28-Jan-22 | 3 | |
| WS-25 | Gas | N | 1.50 | 29-Jan-22 | 0 | |
| WS-26 | Gas | Y | 3.85 | 30-Mar-22 | 0 | |
| WS-27 | Gas | Y | 3.75 | 13-Jun-22 | 44 | CT cable repaired on 26 Jul 22 |
| WS-28 | Gas | N | 3.75 | 15-Jun-22 | 0 | |

Table 4.1 Details of the monitored installations from the Wakefield Mega Solar project

Details of the monitored properties and their installations are provided in table 4.1. The installations took place between 18 Oct 21 and 15 Jun 22, with solar PV system sizes ranging from 1.5kW to 3.85kW.

There were issues with the monitoring at a number of the sites. Installation WS-01 went offline on 1 Jun 22. The installer noted there was an issue with the Wi-Fi dongle and this was replaced. They struggled to get the system back online due to a complex Wi-Fi system involving in home repeaters.

Installation WS-02 went offline on 29 Nov 22. It was not possible to contact this household later in the project, so they may no longer be at the address.



Installations WS-06 and WS-08 both had smart meters fitted and the CT clamp was replaced by the engineer in the wrong orientation. This meant that consumption was recorded as export and vice versa. The installers were able to visit the sites on 20 Jan 22 and fit the CT clamps back in the correct orientation. It is likely that household WS-21 had the CT clamp in late July 2022. There were probably other issues with the cable as the consumption was generally following the generation and it was likely that all readings of consumption and export were inaccurate.

A number of other sites were offline and not collecting data for extended periods. In some cases, this may have been due to switching broadband router. Shorter periods offline might have been due to the broadband router being switched off while residents were away from home. Table 4.1 shows the number of days systems were offline between installation and 31 May 23. This was calculated by either checking missing days of data on the Energy Overview graph or by using the Event History log on the Lux Power portal.

Household WS-11 was unusual as it had 25 short periods where it lost AC connection, making at total of 34.5 days. The duration of these periods could last from about an hour up to several days. The cause was unclear but might have been a technical issue with the system.

There were also installations where the grid and household consumption was incorrectly measured due to issues with the CT clamp or cable. This could result in the household consumption was partially or fully following the solar PV generation. Figure 4.2 for household WS-27 shows an Input & Output Power graph from 19 Jul 22. The household consumption closely followed the solar generation, and no grid import or export was recorded. This issue was resolved on 26 Jul 22 when the CAT5 cable for the CT clamp was replaced. This site subsequently went offline on 17 Apr 23, perhaps when the household changed their broadband router.



Figure 4.2 Issue with Input & Output Power graph for household WS-27 on 19 Jul 22

The monitoring for household WS-10 had similar issues. Figure 4.3 shows that the household consumption followed the solar generation for much of the day on 3 Jun 22, with more normal grid and household consumption overnight. After 16 Jun 22, the monitoring no longer recorded any grid consumption, and the graphs were more like figure 4.2. The issue was likely to be associated with the CT clamp or cable.



Figure 4.3 Issue with Input & Output Power graph for household WS-10 on 3 Jun 22

For household WS-14, an issue developed with the monitoring on 26 Apr 22. From that point, the Consumption closely followed the Solar PV. This was again likely to be an issue with the CT clamp or cable monitoring the household import/export.

This meant that the household consumption, grid consumption and export to grid for households WS-10, WS-14 and WS-27 was likely to be unreliable during the period when there was an issue with the CT clamp or cable.

Installations with periods offline and with the CT clamp reversed meant further periods where there were gaps in the data available to analyse.



4.2. Performance of the solar PV systems

| Ref No | Analysis period | Days offline in period | Solar generation (kWh) | Carbon savings (kgCO ₂ e) | Estimated Generation (kWh) | PVGIS - SARA2 estimate (kWh) |
|--------------|----------------------|------------------------|------------------------|--------------------------------------|----------------------------|------------------------------|
| WS-02 | 1 Nov 21 - 31 Oct 22 | - | 3150 | 609.1 | 2528 | 2816 |
| WS-03 | 1 Jun 22 - 31 May 23 | - | 2928 | 566.1 | 2665 | 2824 |
| WS-04 | 1 Jun 22 - 31 May 23 | - | 3009 | 581.8 | 1739 | 2812 |
| WS-05 | 1 Jun 22 - 31 May 23 | - | 2761 | 533.8 | 2649 | 2843 |
| WS-06 | 1 Jun 22 - 31 May 23 | - | 2653 | 513.1 | 3221 | 3442 |
| WS-07 | 1 Jun 22 - 31 May 23 | - | 4038 | 780.9 | 2994 | 3487 |
| WS-08 | 1 Jun 22 - 31 May 23 | 10 in April | 2280 | 441.0 | 2859 | 2706 |
| WS-09 | 1 Jun 22 - 31 May 23 | 6 in June | 3526 | 681.9 | 2649 | 3616 |
| WS-11 | 1 Jun 22 - 31 May 23 | 3 in June | 3792 | 733.2 | 3191 | 3412 |
| WS-12 | 1 Jun 22 - 31 May 23 | - | 4299 | 831.3 | 3345 | 3650 |
| WS-13 | 1 Jun 22 - 31 May 23 | - | 2700 | 522.2 | 2224 | - |
| WS-15 | 1 Jun 22 - 31 May 23 | - | 3576 | 691.6 | 3084 | 3390 |
| WS-16 | 1 Apr 22 - 31 Mar 23 | - | 3931 | 760.1 | 3326 | 3616 |
| WS-17 | 1 Jun 22 - 31 May 23 | 8 in Jul/Aug | 3239 | 626.4 | 3183 | 3563 |
| WS-18 | 1 Jun 22 - 31 May 23 | - | 2340 | 452.5 | 1714 | 2322 |
| WS-20 | 1 Jun 22 - 31 May 23 | 9 in Sep/Oct | 2000 | 386.7 | 1895 | 2886 |
| WS-23 | 1 Jun 22 - 31 May 23 | 2 in August | 3367 | 651.2 | 3101 | 3305 |
| WS-24 | 1 Jun 22 - 31 May 23 | 1 in June | 1835 | 354.8 | 2425 | 2473 |
| WS-25 | 1 Jun 22 - 31 May 23 | - | 1377 | 266.2 | 1277 | 1322 |
| WS-26 | 1 Jun 22 - 31 May 23 | - | 3257 | 629.9 | 2662 | 2893 |
| WS-28 | 1 Jul 22 - 30 Jun 23 | - | 3880 | 750.4 | 3087 | 3532 |
| Total | | | 63937 | 12364 | 55818 | |

Table 4.4 Performance of monitored solar PV systems compared to estimated generation

The LuxPower monitoring portal was used to assess the generation of the solar PV systems over a 12-month period. Installations where it was not possible to have a 12-month period without extended periods offline or where there were other technical issues with the monitoring were not included in this assessment. This left 21 out of the 28 installations. In most cases the analysis period selected was from 1 Jun 22 – 31 May 23. Other periods were selected if it meant the system was offline for less time.

The measured solar generation was compared to the annual generation estimated by the installers. They were likely to have used the MCS standard method¹¹ for estimating annual generation and take into account shading of the solar panels from trees or other buildings. Another estimate was made by NEA using the PVGIS website with the PVGIS-SARA2 solar radiation database¹². This considered the location of the site and angles of inclination and orientation of the solar panels. It did not consider any impact from shading of the solar panels as this could only be done with a site visit.

¹¹ The Solar PV Standard (Installation), MIS 3002 Issue 5.0, (MCS, 2023), https://mcscertified.com/wp-content/uploads/2023/05/MIS-3002_Solar-PV-Systems-V5.0-Final-for-publication.pdf (Accessed 7 Jul 23)

¹² Photovoltaic Geographical Information System (PVGIS), EU Science Hub, https://re.jrc.ec.europa.eu/pvg_tools/en/ (Accessed 7 Jul 23)



The carbon savings were calculated using the Government Greenhouse Gas conversion factor for 2022. The value for grid electricity was 0.1934kg/kWh¹³. It was assumed that the generation from the solar panels displaced the same amount of electricity from the grid.

Out of the 21 installations analysed, only 3 had a lower value of annual generation than the estimate by the installer. There were 2 potential sources of measuring error with the LuxPower monitoring system. The first was due to periods when the system was offline and this issue would have led to a lower reading for the solar generation. Out of the 7 installations which had periods offline during the analysis period, only 2 installations had lower readings than the estimated generation.

The annual generation of WS-24 was 590kWh lower than the estimate by the installer and 638kWh lower than the estimate using PVGIS. There was only a single day in the analysis period when the installation was offline. The cause of the lower generation was likely to be due to an underestimate of the effect of shading at the site.

The other installation with lower generation was WS-08. This was offline for 10 days in April 2023. However, the annual generation was 579kWh lower than the installer estimate and 426kWh lower than the PVGIS estimate. This was not likely to be solely due to the period offline and there may again have been greater shading of the panels at the site than anticipated.

The second source of error in the measurement of the annual generation was due to the accuracy of the monitoring with the LuxPower hybrid inverter system. This was investigated with the assistance of one of the households. The resident noted that the generation meter had recorded 4,192.2kWh at the same time as the LuxPower monitoring was showing 4,676.5kWh, which was an error of 10.4%. In another study, NEA found the error between the value measured by a Solis inverter and the generation meter for 2 installations was under 2%¹⁴.

The annual generation measured by the LuxPower monitoring outperformed the installer estimate for 18 of the 21 analysed systems. If the LuxPower monitoring overestimated the actual generation by 10% on all the systems, the annual generation would still outperform the installer estimate on 12 of the 21 installations. This ignores any generation lost due to periods when the system was offline.

The total generation measured by the LuxPower monitoring over a year for the 21 installations was 63,937kWh. This compares to a total of 55,818kWh for the installer estimates. Using the measured value for the total generation and the Greenhouse gas conversion factor for electricity, the total carbon equivalent saving for the 21 installations over the year was 12.36 tonnes.

¹³ Greenhouse gas reporting: conversion factors 2022, Department for Energy Security and Net Zero, <https://www.gov.uk/government/publications/greenhouse-gas-reporting-conversion-factors-2022> (Accessed 7 Jul 23)

¹⁴ Rogers and Hamer, (NEA, 2023) Case Studies 1 and 2, Increasing self-consumption of solar PV: Monitors and solar immersion controllers, <https://www.nea.org.uk/wp-content/uploads/2023/06/CP1495-Increasing-Self-Consumption-of-Solar-PV-Small-measures-v2.pdf> (Accessed 7 Jul 23)



The annual generation recorded by the systems ranged from 1,377kWh to 4,299kWh. The lowest generating system had a capacity of 1.5kW. The annual generation was 100kWh above the installer estimate and 55kWh greater than the PVGIS estimate.

The system which recorded the highest generation was WS-12, which had a capacity of 3.8kW and was the second largest installation. The array faced south with an inclination of 35°, which is the optimum for annual generation. The measured annual generation of 4,299kWh was considerably higher than the estimate of 3,345kWh by the installer and 3,650kWh from PVGIS. The annual generation for many of the systems may have benefited from a particularly sunny period in May 2023. However, this probably does not account for such a high level of annual generation. It is possible that a measurement error with the LuxPower monitoring led to a higher value of annual generation. If the value was 10% lower, it would be 3,869kWh, which still outperforms the estimated generation, but is a more likely value.

Other installation which had high levels of measured annual generation included WS-07, WS-16 and WS-28. All of these had 3.75kW installations which were orientated close to due south. Again, the measured annual generation significantly outperformed the estimates of annual generation. It is possible that there was an error again of up to 10% with the LuxPower monitoring system.

The 3.85kW installation for household WS-26 was the largest PV system among the monitored group. The measured annual generation was 3,257kWh, lower than for households WS-07, WS-16, WS-28 and WS-12 which were in the range 3,880-4,299kWh. In this case the installation was split across an approximately east and west facing roof. The orientation of the panels meant there was lower annual generation and less generation in the middle of the day. However, there was likely to have been greater generation in the morning and evening than for a south facing installation. This may help improve the level of self-consumption of the solar generation. Despite the lower generation due to the orientation of the panels, the system again outperformed the estimates of annual generation of 2,662kWh from the installer and 2,893 from PVGIS.



4.3. Self-consumption of the solar generation

| Ref No | Analysis period | Solar generation (kWh) | Export to grid (kWh) | Household consumption (kWh) | Self consumption (%) | Time at home |
|--------|----------------------|------------------------|----------------------|-----------------------------|----------------------|-----------------|
| WS-02 | 1 Nov 21 - 31 Oct 22 | 3150 | 2613 | 1639 | 17.0% | |
| WS-03 | 1 Jun 22 - 31 May 23 | 2928 | 2234 | 2466 | 23.7% | Home all day |
| WS-04 | 1 Jun 22 - 31 May 23 | 3009 | 1389 | 2147 | 53.8% | Home all day |
| WS-05 | 1 Jun 22 - 31 May 23 | 2761 | 2599 | 1391 | 5.9% | In half the day |
| WS-06 | 1 Jun 22 - 31 May 23 | 2653 | 1634 | 8596 | 38.4% | Home all day |
| WS-07 | 1 Jun 22 - 31 May 23 | 4038 | 3017 | 1927 | 25.3% | Home all day |
| WS-08 | 1 Jun 22 - 31 May 23 | 2280 | 1715 | 2367 | 24.8% | In half the day |
| WS-09 | 1 Jun 22 - 31 May 23 | 3526 | 2973 | 2285 | 15.7% | In half the day |
| WS-11 | 1 Jun 22 - 31 May 23 | 3792 | 3158 | 1942 | 16.7% | Home all day |
| WS-12 | 1 Jun 22 - 31 May 23 | 4299 | 2070 | 6310 | 51.8% | Home all day |
| WS-13 | 1 Jun 22 - 31 May 23 | 2700 | 1127 | 4631 | 58.3% | Home all day |
| WS-15 | 1 Jun 22 - 31 May 23 | 3576 | 2578 | 2702 | 27.9% | Home all day |
| WS-16 | 1 Apr 22 - 31 Mar 23 | 3931 | 2585 | 5121 | 34.2% | Home all day |
| WS-17 | 1 Jun 22 - 31 May 23 | 3239 | 1478 | 8929 | 54.4% | Home all day |
| WS-18 | 1 Jun 22 - 31 May 23 | 2340 | 1437 | 2579 | 38.6% | |
| WS-20 | 1 Jun 22 - 31 May 23 | 2000 | 1844 | 1667 | 7.8% | In half the day |
| WS-23 | 1 Jun 22 - 31 May 23 | 3367 | 2366 | 3811 | 29.7% | |
| WS-24 | 1 Jun 22 - 31 May 23 | 1835 | 1405 | 1824 | 23.4% | In half the day |
| WS-25 | 1 Jun 22 - 31 May 23 | 1377 | 612 | 7181 | 55.6% | Home all day |
| WS-26 | 1 Jun 22 - 31 May 23 | 3257 | 1312 | 3778 | 59.7% | Home all day |
| WS-28 | 1 Jul 22 - 30 Jun 23 | 3880 | 2730 | 4428 | 29.7% | Home all day |

Table 4.5 Data from the LuxPower portal and self-consumption of solar generation

Annual values for solar generation, export to grid and household consumption are shown in table 4.5 based on data from the LuxPower portal. The values of solar generation and export to grid were used to calculate the percentage self-consumption of the solar generation. Also shown is the amount of time residents are typically at home. This along with the solar generation and grid consumption can be used to estimate the level of self-consumption¹⁵.

The installations which are highlighted in a darker colour had battery storage added by the residents after the solar PV was fitted. This led to higher levels of self-consumption of the solar generation, with each system achieving between 50 and 60% self-consumption.

The lowest levels of self-consumption were with installations WS-05 (5.9%) and WS-20 (7.8%). Household WS-05 was in half the day and had the lowest household consumption (1391kWh) among those recorded in table 4.5. Figure 4.6 shows an Input & Output graph from the LuxPower portal for household WS-05. It was a sunny day with the generation from the solar panels following a bell-shaped curve. There were 2 brief peaks of consumption in the morning and a peak in consumption in the late afternoon which were part powered by the

¹⁵ Solar PV Self-Consumption – A method to determine the Electrical Self-Consumption of Domestic Solar PV Installations with and without Storage, MCS Guidance Document MGD 003 Issue 2.0, MCS (2022), <https://mcs-certified.com/wp-content/uploads/2022/04/MGD-003-Solar-PV-Self-Consumption-Issue-2.0-Final.pdf> (Accessed 10 Jul 23)



solar panels. The baseload consumption was about 70 – 140W. There was limited self-consumption of the solar generation that day with 20.2kWh generated and 18.8kWh exported to the grid.

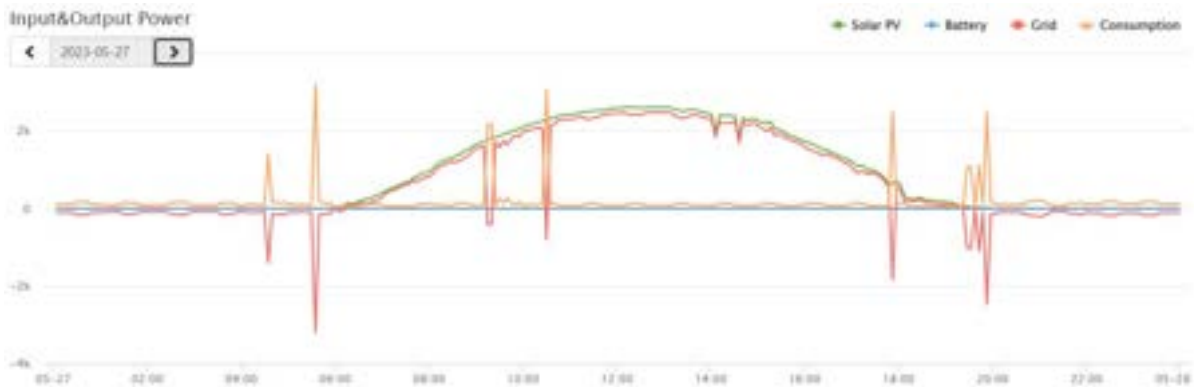

Figure 4.6 Input & Output Power graph for household WS-05 on 27 May 23

The household consumption for WS-20 was 1667kWh, which was the second lowest of the installations in table 4.5. The residents were also in half the day which limited the daytime consumption of solar generation. This contributed to the low self-consumption of 7.8%.

The self-consumption of the households that were in half the day ranged from 5.9% to 24.8%. For households that were at home all day and did not have a battery, the self-consumption was between 16.7% and 55.6%. There were 5 households who noted they were at home all day whose self-consumption was above 30%. The highest self-consumption of 55.6% was for WS-25. This household had the smallest PV system and lowest generation while also having the third highest consumption.

Household WS-17 had 5 residents and the highest household consumption (8,929kWh). The self-consumption of the solar generation was 54.4%, the second highest among the analysed group without batteries. Figure 4.7 shows an example Input & Output Power graph from 12 June 23. The grid import/export is not included to assist with interpretation. The baseload consumption was 700-800W. There were periods of 2 hours or more with peaks in consumption of 1,800-2,000W. There were also short consumption peaks of over 5,000W, which were likely to be due to an electric shower. There was a high baseload with additional peaks of consumption throughout the year. The monthly self-consumption ranged from 46.8% in March 2022 to 60.2% in December 2022.



Figure 4.7 Input & Output Power graph for household WS-17 on 12 Jun 23

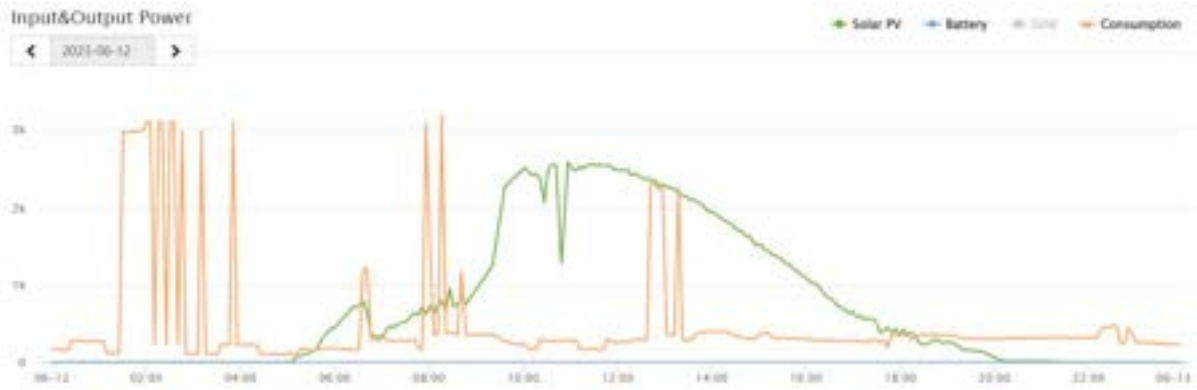

Figure 4.8 Input & Output Power graph for household WS-06 on 12 Jun 23

Household WS-06 had the second highest household consumption (8,596kWh) in the analysed group. Most of the consumption took place overnight due to having electric storage heaters and water heating and the household was likely to be on an Economy 7 tariff. The Input & Output Power graph in figure 4.8 has high consumption overnight due to the electric immersion heater, with an initial 40 minutes at 3kW, followed by some shorter bursts overnight to maintain the water temperature. The baseload consumption was 170-300W for much of the rest of the day, with some consumption peaks in the morning at around 8am and 1pm, which might be due to use of electrical appliances at mealtimes. Although the majority of the electrical consumption was overnight and in winter, the household still managed a rate of self-consumption of 38.4%.

There were 2 other properties which did not have batteries which had levels of self-consumption above 50%. Household WS-25 had the third highest household consumption (7,181kWh) and the lowest solar generation (1,377kWh). This installation had the highest self-consumption (55.6%) among properties which did not have a battery fitted. The property with the highest generation of 4,299kWh was WS-12. This also had the fourth highest household consumption of 6,310kWh, with a typical baseload electricity consumption of 500 – 600W. The percentage self-consumption ranged from 78.2% in January 2022 to 42,6% in August 2022, with an average over the year June 2022 to May 2023 of 51.8%

Household WS-03 had a fairly average solar generation of 2,928kWh and household consumption of 2,466kWh. The household was typically at home all day and had 2 residents. Figure 4.9 shows an Input & Output Power graph for the same day as figures 4.8 and 4.7.



Figure 4.9 Input & Output Power graph for household WS-03 on 12 Jun 23



The baseload electricity consumption for WS-03 was typically 70 – 230W, which was considerably lower than for household WS-17. On 12 Jun 23, there was a peak of nearly 3kW at 10:20 which might have been due to an appliance like a kettle. There was a sustained peak of 2,100W from 15:15, which rose to about 5kW at 15:45. There was a further peak of about 2,100W for 15 minutes from 20:15 in the evening. Overall that day, the solar generation was 21.4kWh, with 17.9kWh exported to the grid (16.4% self-consumption) and a household consumption of 5.9kWh.

The grid consumption should be:

$$\text{Grid consumption} = \text{Household consumption} - (\text{Solar generation} - \text{Export to grid})$$

Using the data from the LuxPower portal for the period 1 Jun 22 to 31 May 23, the grid consumption over the year would be 1,772kWh. The household also provided meter readings for the period 24 May 22 to 24 May 23 where the grid consumption was 1,446kWh. Some discrepancy would be expected between the LuxPower data and the smart meter data due to the start and finish dates differing by about a week. However, this data is larger than might be expect by the differing dates alone and measurement errors due to the LuxPower monitoring may be a greater factor in the cause of the differing readings.

4.4. Impact of adding battery storage

| Ref No | Analysis period | Battery installation date | Battery model | Battery capacity (kWh) | Battery charge (kWh) | Self consumption (%) |
|--------|----------------------|---------------------------|---------------|------------------------|----------------------|----------------------|
| WS-04 | 1 Jun 22 - 31 May 23 | 11-Dec-21 | Pylon Tech | 3.2 | 670 | 53.8% |
| WS-13 | 1 Jun 22 - 31 May 23 | 17-Oct-22 | Uhome | 2.4 | 251 | 58.3% |
| WS-26 | 1 Jun 22 - 31 May 23 | 29-Mar-22 | - | - | 598 | 59.7% |
| WS-27 | 1 Oct 22 - 16 Apr 23 | 06-Oct-22 | Green Lynx | 9.6 | 1781 | - |

Table 4.10 Details of batteries installed by households and their performance

The Wakefield Mega Solar project fully funded the solar PV systems for households that met the eligibility criteria. Those in the monitored group had a LuxPower hybrid inverter which was able to act as the inverter for a battery as well as the solar PV. 4 of the 28 households in the monitored group chose to fund installation of a battery system to go with the solar PV.

Household WS-04 had a Pylon Tech battery fitted on 11 Dec 21, a month and a half after the solar PV system was installed. The battery was likely to be a Pylon Tech US3000C with a total capacity of 3.55kWh and usable capacity of 3.2kWh. It was operating over the full monitoring period of 1 Jun 22 – 31 May 23 and the battery charge was 670kWh. Overall, the self-consumption of the solar generation was 53.8% for the household.

A Uhome battery was installed for household WS-13 on 17 Oct 22, part way through the analysis period. The battery was likely to be a Uhome LFP 2400, with a nominal capacity of 2.4kWh and usable capacity of 2.2kWh. The nominal charge/discharge power was 1.5kW, but it could discharge up to 3kW for 3 seconds. The lower battery charge of 251kWh was primarily due to the battery being installed part way through the analysis period. However, this battery also had a lower capacity and input/output power than the Pylon Tech battery which would also have lowered the battery charge.



The details of the battery installed by household WS-26 are not known. Performance of the battery suggests it may have had a capacity of about 3kWh and a maximum charge and discharge power of approximately 1.3kW. Overall, this household had the highest level of solar self-consumption (59.7%) among the 21 properties which were analysed in depth. This was likely to be due to a combination of a fairly high daytime household consumption (total of 3,778kWh), having an east-west solar PV installation along with the battery installation.

There was limited monitoring data available for household WS-27. There were issues with the CT clamp for the monitoring until 26 Jul 22 and the system was offline after 16 Apr 23. The household had 3 x 3.2kWh Green Lynx batteries fitted on 6 Oct 22. The system had been set to charge both from the solar PV and the grid using off-peak Economy 7 electricity. The battery could charge at about 3.5kW and discharge at about 3kW. The high level of battery charge (1,781kW) between 6 Oct 22 and 16 Apr 23 was due to WS-27 having a much larger battery than the other households and using it for grid charging as well as from the solar PV. This meant much of the power used by the home could come from the battery or the solar PV during the period for peak rate electricity.

Figure 4.11 shows an Input & Output Power graph for household WS-27 on 24 Oct 22. The household consumption is not shown for clarity. When there was consumption from the grid (in red) and charging of the battery (in blue) it is negative. Export to the grid and battery discharge is positive. The battery charged from the grid from about 00:30 to 03:15. From 07:30, the battery started providing power to the home. There was recharging of the battery by the solar PV from about 10:30 to about 15:00. After that, the battery provided most of the power to the home until midnight. There was a major spike in grid consumption at 18:50 when either multiple appliances were used or an electric shower. The battery provided 3kW while a further 4.6kW was supplied by the grid. Over the day, there was 4kWh of solar generation, the battery charge was 9.3kWh, only 0.3kWh was exported to the grid and the household consumption was 14.9kWh.



Figure 4.11 Input & Output Power graph for household WS-27 on 24 Oct 22

Table 4.12 shows monthly data from the LuxPower monitoring portal and calculated values for the self-consumption of the solar generation. The battery was not installed until 6 Oct 22, so there was a relatively high level of export in August 2022 (219.4kWh) with 42% of the generation used in the home. In September 2022, the solar generation decreased to 218 kWh and the household consumption increased to 431.5kWh, leading to quite a high level of self-consumption of 58.7% without a battery. After the battery was fitted, the monthly export to the grid decreased to 4.8 – 13.6kWh for the remaining months analysed.



| Ref No | Month | Solar generation (kWh) | Battery charge (kWh) | Export to grid (kWh) | Household consumption (kWh) | Self-consumption (%) |
|--------|--------|------------------------|----------------------|----------------------|-----------------------------|----------------------|
| WS-27 | Aug-22 | 378.0 | 0.0 | 219.4 | 364.0 | 42.0% |
| | Sep-22 | 218.0 | 0.0 | 90.0 | 431.5 | 58.7% |
| | Oct-22 | 116.7 | 203.4 | 9.4 | 439.3 | 91.9% |
| | Nov-22 | 50.8 | 242.9 | 5.8 | 396.1 | 88.6% |
| | Dec-22 | 36.0 | 270.1 | 4.8 | 443.7 | 86.7% |
| | Jan-23 | 57.3 | 264.9 | 7.0 | 434.5 | 87.8% |
| | Feb-23 | 87.1 | 237.5 | 8.2 | 416.7 | 90.6% |
| | Mar-23 | 155.5 | 234.5 | 13.6 | 440.8 | 91.3% |

Table 4.12 Monthly data from the LuxPower monitoring portal for household WS-27

The large battery installed at WS-27 led to the low levels of export to the grid and high rates of self-consumption. This ranged from 86.7 to 91.9% after the battery was fitted.

Figure 4.13 shows an Input & Output Power graph for household WS-13 on 12 Jun 23. This household had a smaller battery with a 2.2kWh usable capacity and 1.5kW charge/discharge rate. The battery had fully discharged the previous day which meant there was grid consumption from midnight. There was a small amount of grid charging of the battery from 04:00 to 05:00 and this was subsequently discharged, lowering the grid consumption. There were sharp negative peaks of grid consumption at 08:30 (perhaps due to a kettle) and at 09:40. The battery was charging from 10:00 as the solar generation increased. Power from the battery was provided to the home briefly at 12:15 and the battery started charging again until it was fully charged at 12:50. There were short periods of further recharging at 14:00 and 17:20. The battery provided most of the power for the home through the evening. Grid import was required at 19:30 when the household consumption of 2.5kW was greater than the battery output of 1.5kW.

A graph of the monthly electricity import is shown in figure 4.14. The data from 2018 to 2020 shows the electricity import prior to the solar PV and battery system being fitted. The electricity import ranged from 638kWh in January 2020 to 301.5kWh in May 2019, although the value of 418.7kWh in May 2018 was more typical of the trend in electricity import than the lower value for May 2019. There was a significant drop in electricity import in 2023 compared to the previous years, with the monthly values ranging from 346kWh to 92.7kWh.



Figure 4.13 Input & Output Power graph for household WS-13 on 12 Jun 23

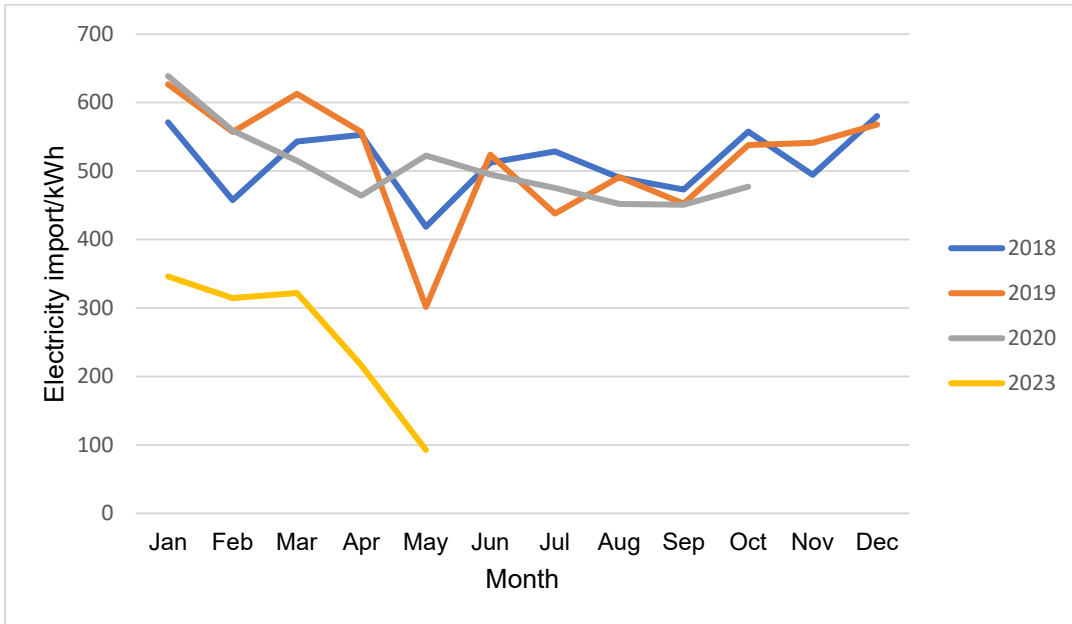

Figure 4.14 Graph of electricity import per month for household WS-13 from smart meter data

Addition of the solar PV system and battery (fitted on 17 Oct 22) will be the primary cause of the reduced electricity import in 2023 compared to earlier years. However, it is unknown whether other factors may have also contributed such as installation of more energy efficient appliances or periods away from home.

4.5. Cost savings from the solar PV and battery systems

It is possible to estimate the cost savings from the amount of the consumption of the solar generation (i.e. generation – export). For households with batteries, this is an overestimate of the electricity from the solar used in the home as there are losses through the battery charging and discharging. Greater errors in the estimates are likely to come from the data derived from the LuxPower monitoring system. It was noted that the generation meter reading for one household was 10.4% lower than the reading from the LuxPower monitoring.

During the analysis period, the Default Tariff Price Cap was about 28p/kWh and later the Energy Price Guarantee was about 33p/kWh. An electricity price of 30p/kWh was therefore used to estimate the annual electricity savings households made following installation of the solar PV system.

In addition to savings from reduced electricity consumption, some households also signed up for payments from the Smart Export Guarantee (SEG). The SEG tariff rate varied between electricity suppliers. For some suppliers it was as low as 3p/kWh, while a few offered 15p/kWh on some tariffs. A conservative rate of 5p/kWh was chosen to estimate the export payments since only a few suppliers were offering the highest rates during the study.

Table 4.15 shows the estimated annual electricity savings and export payments along with the data used to calculate them. The annual electricity savings ranged from £46.83 to £668.58, while the smart export guarantee payments were between £30.59 and £157.92. The export payment could be 3 times higher than these values if the household was signed up for the most generous SEG tariff.



| Ref No | Solar generation (kWh) | Export to grid (kWh) | Consumption of solar generation (kWh) | Electricity tariff rate | Annual saving (£) | SEG rate | Export payment (£) |
|--------|------------------------|----------------------|---------------------------------------|-------------------------|-------------------|----------|--------------------|
| WS-02 | 3150 | 2613 | 536.5 | 30p / kWh | £160.95 | 5p / kWh | £130.66 |
| WS-03 | 2928 | 2234 | 693.9 | 30p / kWh | £208.17 | 5p / kWh | £111.69 |
| WS-04 | 3009 | 1389 | 1619.1 | 30p / kWh | £485.73 | 5p / kWh | £69.47 |
| WS-05 | 2761 | 2599 | 161.6 | 30p / kWh | £48.48 | 5p / kWh | £129.95 |
| WS-06 | 2653 | 1634 | 1019.6 | 30p / kWh | £305.88 | 5p / kWh | £81.69 |
| WS-07 | 4038 | 3017 | 1020.7 | 30p / kWh | £306.21 | 5p / kWh | £150.87 |
| WS-08 | 2280 | 1715 | 565.0 | 30p / kWh | £169.50 | 5p / kWh | £85.77 |
| WS-09 | 3526 | 2973 | 552.9 | 30p / kWh | £165.87 | 5p / kWh | £148.66 |
| WS-11 | 3792 | 3158 | 633.4 | 30p / kWh | £190.02 | 5p / kWh | £157.92 |
| WS-12 | 4299 | 2070 | 2228.6 | 30p / kWh | £668.58 | 5p / kWh | £103.51 |
| WS-13 | 2700 | 1127 | 1572.8 | 30p / kWh | £471.84 | 5p / kWh | £56.37 |
| WS-15 | 3576 | 2578 | 998.1 | 30p / kWh | £299.43 | 5p / kWh | £128.92 |
| WS-16 | 3931 | 2585 | 1345.4 | 30p / kWh | £403.62 | 5p / kWh | £129.27 |
| WS-17 | 3239 | 1478 | 1761.7 | 30p / kWh | £528.51 | 5p / kWh | £73.88 |
| WS-18 | 2340 | 1437 | 902.3 | 30p / kWh | £270.69 | 5p / kWh | £71.87 |
| WS-20 | 2000 | 1844 | 156.1 | 30p / kWh | £46.83 | 5p / kWh | £92.19 |
| WS-23 | 3367 | 2366 | 1001.5 | 30p / kWh | £300.45 | 5p / kWh | £118.29 |
| WS-24 | 1835 | 1405 | 430.0 | 30p / kWh | £129.00 | 5p / kWh | £70.23 |
| WS-25 | 1377 | 612 | 765.0 | 30p / kWh | £229.50 | 5p / kWh | £30.59 |
| WS-26 | 3257 | 1312 | 1945.2 | 30p / kWh | £583.56 | 5p / kWh | £65.61 |
| WS-28 | 3880 | 2730 | 1150.5 | 30p / kWh | £345.15 | 5p / kWh | £136.49 |

Table 4.15 Electricity savings and export payments based on data from the LuxPower monitoring

Household WS-12 had the highest solar generation and the greatest consumption of the solar generation (2228.6kWh). This led to the greatest electricity savings of £668.58 and the greatest financial benefit when combining electricity savings and export payments, with a total benefit of £772.09.

The households with the lowest electricity savings were WS-20 and WS-05 which had rates of self-consumption of only 7.8% and 5.9%. This resulted in electricity savings of only £46.83 and £48.48 respectively. For these households, it was important to have signed up to the export tariff as these payments would have been greater than the electricity savings, taking the total benefit up to £139.02 and £178.43 respectively.

The households that fitted batteries had some of the highest electricity savings. The savings for WS-04, WS-13 and WS-26 were £485.73, £471.84 and £583.56 respectively. The export payments were small and in the range £56.37 to £69.47.

Another household to make high savings was WS-17 which had the highest household consumption and the third highest consumption of the solar generation. This resulted in electricity savings of £528.51.

Several of the households noted in the questionnaire that they found the Smart Export Guarantee too difficult to sign up for or that it was not worth it for the rate of 3p/kWh offered by their supplier. There were 11 households where the export payment was over £100. Had these households been on the most generous tariff rather than 5p/kWh, this could have led to export payments of over £300.



In some situations, it may be more valuable to the household to make greater use of the solar generation rather than be paid what could be a relatively small amount (3p – 15p/kWh) for electricity exported to the grid.

Households might install battery storage like the 4 in the monitored group. The capacity of batteries has been increasing and many will now charge and discharge at 3kW or more. The economics for battery storage has been improving in recent years. The cost per kWh of storage has been decreasing and the cost of electricity rose significantly in the energy crisis following the COVID pandemic and the war in Ukraine. Many new domestic solar PV installations have recently included a battery. This has been partly due to lower installation costs from using a hybrid inverter, but also because installing a battery at the time of the solar PV installation attracted 0% VAT. Retrofitting a battery to an existing solar PV system at the time of writing had a VAT rate of 20%. The solar industry has lobbied for battery retrofits to also be at 0% VAT. There is likely to be a significant increase in retrofits of battery storage systems should there be a change in the VAT rate. Another incentive for installation of batteries will be when the methodology for calculating EPCs takes into account the benefit of battery storage and it improves the energy score. The update to the methodology for EPCs for existing buildings is likely to occur in 2024.

A cheaper way to use excess solar generation could be a solar diverter. This includes devices like the myenergi zappi EV charger, which has a setting where you can use only the excess solar generation to charge an electric vehicle. There are also solar diverters which can use excess solar generation to power the immersion heater in a hot water cylinder. Examples of this include the myenergi eddi and the Marlec Solar iBoost¹⁶. Households could alternatively install a smart hot water cylinder manufactured by Mixergy which can include a solar immersion controller.

Households WS-06 and WS-10 in this project had electric storage heaters. They were also likely to have a cylinder where the water was heated by Economy 7 off-peak electricity. The households should be able to save money using a solar diverter to power the immersion heater thereby purchasing less off-peak electricity for water heating. Whether savings would be made depends on the normal cost of the water heating (which might be 15p/kWh on Economy 7 off-peak) compared to the amount paid for the export tariff, which could range from less than 3p/kWh to 15p/kWh depending on the electricity supplier at the time of writing. Solar immersion controllers can typically fully heat a water cylinder most days between March and October and can also provide some heating in winter depending on the level of solar generation and household consumption.

¹⁶ Rogers and Hamer, (NEA, 2023), Increasing self-consumption of solar PV: Monitors and solar immersion controllers, <https://www.nea.org.uk/wp-content/uploads/2023/06/CP1495-Increasing-Self-Consumption-of-Solar-PV-Small-measures-v2.pdf> (Accessed 14 Jul 23)



5. Conclusions

Installation programme

- There were 115 installations in the Wakefield Mega Solar project, with systems installed between 14 Oct 21 and 20 Sept 22
- There were 90 installations where the system size was between 3.0 and 3.99kW and 15 installation sized between 1.5 and 2.74kW
- There were 16 installations where the solar panels were split between roofs facing different directions and 99 installations where the panels were in an array facing a single direction
- Out of the 115 installations, 68 had an estimated annual generation of between 2,500 and 3,500kWh and 23 had an estimated annual generation of between 1,000 and 2,000kWh

Social analysis of the monitored group

- Out of the 24 households that completed a questionnaire, 23 were happy with their solar PV installation and would recommend it to their friends
- The LuxPower inverter had a monitoring app and 22 of the 24 households were using it, while 21 found the app useful
- Households used the app to monitor generation and household consumption and to know when to use high power appliances
- 14 of the 24 households used the LuxPower app at least once a day
- 17 of the 24 households thought they were saving a lot with the solar panels
- 23 of the 24 households were more aware of how they used electricity and 21 had changed the way they used electricity
- 19 households said they tried to use high power appliances when it was sunny outside while 18 tried to use appliances during the day rather than at night
- 20 of the 24 households were aware of the smart export guarantee, but many found it difficult to sign up and some did not bother because they felt the payments would be so low
- The feedback from the households about the project was generally very good. Examples include:
 - “It has been a very positive experience and we work with the solar to make the most of it”
 - “From application to having the panels fitted went like a dream. The lady from the Council was fantastic. Everything from start to finish was positive. I cannot praise them enough. It has been a really, really positive experience”
- There were also a few negative points that came out in the comments
 - “Too many hoops to go through and at one point I nearly gave up because of the slow progress. Far too much red tape”
 - A household commented on a cracked tile and another noted the scaffolding was left in place for several weeks and they had to ask for it to be taken down
 - Another household felt they had seen little benefit moneywise, but their monitoring system had lost connection with their Wi-Fi



Monitoring of installations

- A LuxPower hybrid inverter was installed for the 28 households who were part of a the monitored group
- The LuxPower system monitored the solar generation through the inverter and a CT clamp was fitted around a cable of the household supply to measure the import and export of electricity
- There were issues with the CT clamps on some installations
 - Some households had smart meters fitted and the engineer replaced the CT clamp in the wrong orientation, causing electricity import to be recorded as export and vice versa.
 - There were other issues with the CT clamp or cable which meant for some installations no grid import/export was recorded
- The generation from the LuxPower monitoring app was compared with the reading on the generation meter for one household. The app had recorded 4,677kWh compared to 4,192kWh on the generation meter, a difference of 10.4%

Analysis of the performance of systems

- Out of the 28 households in the monitored group, there were 21 which had a 12-month period with good Wi-Fi connectivity and no technical issues
- The annual generation from the LuxPower monitoring was greater than the installer estimates for 18 out of the 21 analysed systems
- Even if the LuxPower monitoring overestimated the generation by 10%, 12 out of the 21 installations would have outperformed the installer estimates during the monitoring period
- The total generation of the 21 analysed systems over a 12-month period was 63,937kWh with a carbon saving of 12.36 tonnes using the 2022 conversion factor for grid electricity
- The lowest levels of self-consumption were 5.9% and 7.8% for households who were in half the day and had low levels of household consumption
- Several of the households had self-consumption rates of 50-60%. This was due to high levels of household consumption (during the day) or households having added battery storage
- There were 4 households who subsequently added their own battery storage system
 - The batteries ranged in size from 2.2kWh to 9.6kWh usable capacity
 - 3 of the battery systems charged predominantly from the solar PV and the households had self-consumption levels of 53.8 to 59.7%
 - The household with the largest battery (9.6kWh) was on an Economy 7 tariff and charged the battery using off-peak electricity as well as from the solar
 - Limited data was available for the largest battery but rates of self-consumption of the solar generation were in the range 86.7 to 91.9% between October 2022 and March 2023
- Households could benefit from using the free electricity from the solar panels and being paid for electricity exported to the grid
 - When estimating the total financial benefit, an electricity tariff of 30p/kWh was used and a Smart Export Guarantee rate of 5p/kWh



- The household with the greatest electricity savings of £668.58 had the highest solar generation and the greatest consumption of solar generation
- Other households with particularly high electricity savings were the 3 with batteries which were monitored over the year. These savings ranged from £471.84 to £583.56
- The 2 households with the lowest rates of self-consumption saved £46.83 and £48.48 on their electricity. Greater savings would have come from payments for electricity export, with £92.19 and £129.95 respectively
- The export payments for the 21 analysed households were estimated to be between £56.37 and £157.92 for a Smart Export Guarantee (SEG) rate of 5p/kWh
- SEG rates vary considerably between suppliers from under 3p/kWh to 15p/kWh or more. This means the household with the highest export could have been paid as much as £473.70 if they were on the most attractive export tariff
- If there are high levels of export from the solar PV system or the export tariff is not attractive, households might consider methods to increase their self-consumption of the solar generation, such as battery storage or diverters like solar immersion controllers



6. Appendix

6.1. Appendix 1 - Wakefield Council recruitment letter

www.wakefield.gov.uk

Our Ref Mega Solar Scheme
Reply to Energy Team
Telephone 01924 305887
Email EnergyTeam@wakefield.gov.uk



Corporate Director: Mark Lynam

Economic Growth & Skills
Service Director: Clare Elliott
Wakefield One
Burton Street
Wakefield
WF1 2EB
Typetalk calls welcome

June 2021]

Name
Address
Address
Address

Dear Resident

WAKEFIELD MEGA SOLAR SCHEME – FREE SOLAR ELECTRIC SYSTEM

Wakefield Council's exciting new scheme to help reduce your fuel bills and improve your home energy efficiency is now live.

The Mega Solar Scheme offers free solar photovoltaic (PV) electric panels to qualifying properties across the Wakefield district. The solar panels will produce electricity that can be used in your home, using the electricity produced by the panels will help reduce your electricity bill. If you qualify for the scheme the solar panels and equipment will belong to you, plus you will get all the benefits from the system, this scheme is **not** a 'rent a roof'.

To qualify, you need to meet **ALL** the following criteria:

- You are a homeowner (owner occupier) living in the Wakefield district
- Your total annual household income is £30,000 GROSS or less (including all benefits)
- You live in a domestic house or bungalow with its own pitched roof and loft access
- Your home has a poor energy efficiency rating (Band D-G), shown via a valid Energy Performance Certificate (EPC). Don't worry if you are unsure on your EPC rating, the form below will help us work this out for you. We are also asking for those who already have EPC certificates to complete and return the form, you may find any upgrades undertaken since the issue date will make the rating invalid.
- You will need to have cavity wall and loft insulation (where applicable), but where this is not installed, help may be available.

This offer is available for a limited time only and would recommend you apply today. If you would like to be considered for the scheme, please complete the enclosed Property Form and send it back using the enclosed return envelope.

If you would like to complete an electronic version, please email us and we can send the form to you.

If you qualify, all work is delivered by the Council's approved contractors.



working for you



What happens next?

Once we receive your completed form, we will carry out additional checks to see if your property meets the schemes EPC requirement (D-G). Once we have conducted these checks, we will be in touch and let you know if we can take your application further. If you need any help with the form, please get in touch and we will do our best to help.

The eligibility criteria for the scheme is set by Government and aims to target the most vulnerable households in fuel poverty. Sadly, we have no control over the criteria.

We are restricted on the amount of EPC D ratings we can put through for the scheme. At the moment we are putting D-rated properties on a waiting list and completing full applications when the scheme allows. Unfortunately, it is possible that some households will be disappointed at a later stage if the number of EPC D properties is too high and exceeds the schemes policy.

If you know that your property is D rated and don't want to go any further, you don't need to return the attached property form.

If you would like any further information or would like to apply for the scheme, please contact the Energy Team on 01924 305887 or email at energyteam@wakefield.gov.uk

Thank you for your patience.

Yours sincerely

A handwritten signature in black ink, appearing to read 'Sarah Johnson', written in a cursive style.

SARAH JOHNSON
Energy Project Manager



working for you



Action for Warm Homes

www.wakefield.gov.uk

wakefieldcouncil

Regeneration & Economic Growth

Mega Solar Scheme Property Form

Contact Details

Full Name: _____ Date: _____

Address: _____

Phone: _____ Email: _____

Property Type

Year Built: _____ (Please give an estimation if unsure)

- Detached
- Semi Detached
- End Terrace
- Mid Terrace
- Detached Bungalow
- Semi Bungalow
- Flat

Rooms in your home

Please tick all the boxes which apply to your home.

- Living Room
- Lounge Diner
- Lounge
- Kitchen Diner
- Kitchen
- Dining Room

How many bedrooms do you have in your home? _____

How many floors? (excluding cellar & loft) _____

Is your loft converted into a bedroom? _____



working for you



Heating in your home

Before you continue, please look at the examples below, these show common heating systems:



This is a condensing combi boiler. You can easily identify this boiler by the plastic pipework



This is a combi boiler. You can see there is no plastic pipework coming from this boiler.



This is a standard gas boiler. You will have a separate boiler and hot water tank.

What fuel do you use to heat your home? What type of heating system do you use?

- Gas
- Solid Fuel
- Oil
- Electric
- LPG

- Condensing Combi
- Combi
- Coal Boiler
- Standard / Back Boiler
- Standard Condensing

Not Listed (Please specify) _____

Approximately how old is your heating system? _____

Do you have any heating controls? Please select ONE

- No Controls
- Timer Only
- Timer & Room Thermostat Only
- Time & Room Thermostat & TRV's



working for you



Do you have any additional heating appliances?

- Wood Burner
- Gas Fire
- Electric Fire

Other: _____

Do you have a hot water cylinder / tank? Yes No

Cylinder / Tank Size?

- Normal 90-130 L
- Medium 131-170 L
- Large 170 L +



Is the tank insulated? Yes No

Approximately how thick is the insulation? _____ MM

- Foam
- Jacket

Is there a cylinder thermostat present? (Normally 3rd of the way up the cylinder) Yes No

If you don't have a cylinder, how do you heat your water?

- Gas Multi Point
- Solar Thermal

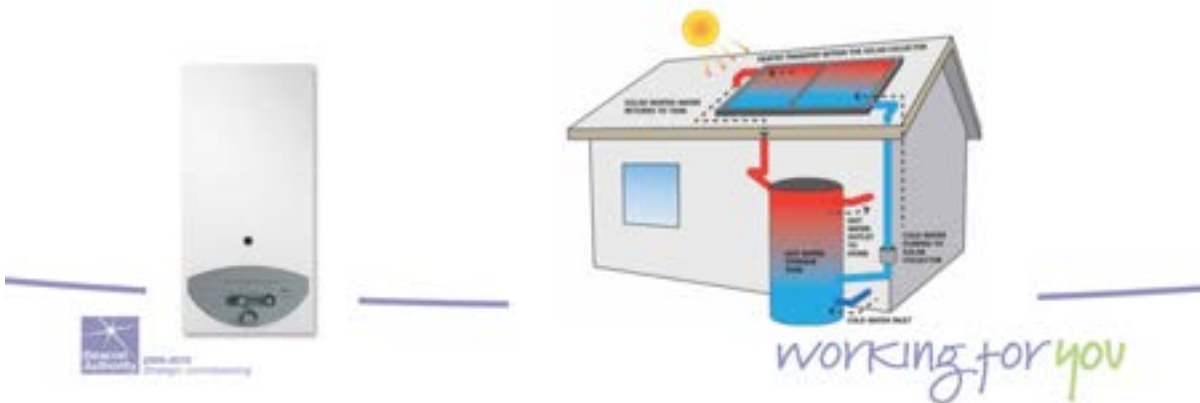



Insulation in your home

Do you have loft insulation? Yes No

How thick is your loft insulation? _____ MM

If you are unsure, can you describe it? _____

Before you continue, please look at the examples, these show common wall construction.



This is a cavity wall; you can identify if you have cavity wall by looking at the brick layout. The bricks will be long and follow this pattern. There should be no other brick sizes.

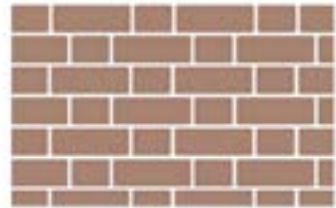

This is a solid brick; you can identify if you have solid brick by looking at the brick layout. The bricks will be long and short and follow this pattern.

What type of wall is your property constructed of?

Type of wall insulation

- Cavity Wall
- Solid Brick
- Solid Stone
- Timber Frame
- Concrete / Non-Traditional

- Cavity Wall Insulation
- Solid Wall Internal
- Solid Wall External
- None

Floors (Ground) Timber Solid

If timber, is it insulated? Yes No

Windows – What percentage are double/multi glazed? _____ %

Lighting – How many fixed light fittings? _____ How many have energy efficiency bulbs? _____



working for you



Action for Warm Homes

6.2. Appendix 2 – Information sheet for NEA project evaluation



Information sheet

Introduction

Solar PV systems are being provided to residents under the Wakefield Mega Solar Scheme. Wakefield Council has commissioned National Energy Action (NEA), the national fuel poverty charity to evaluate the benefits of the scheme for residents receiving installations.

As part of this evaluation, NEA will be looking to monitor the amount of electricity the solar panels produce, how much of that electricity is used in the home and the overall household electricity consumption. There will also be analysis of your own views of the PV system.

You are invited to take part:

We aim to engage with 50 households who receive solar PV systems to participate in the evaluation. The study will take place from the time the solar panels are installed until the end of 2022. At the end of the study, we will contact you to ask you some questions about the difference the solar PV system has made for you. This will be in the form of an online questionnaire, although telephone interviews or paper questionnaires are also available.

Will I receive anything for taking part?



Yes! We will upgrade you to a premium quality solar PV inverter that will provide you with the ability to closely monitor the performance of your new solar PV system and how it affects your household electricity consumption.

At the end of the evaluation, if you complete the final questionnaire, we will enter you into a prize draw. The first prize is £150 in shopping vouchers, the second prize will be £100 and a third prize of £50.

NEA can also provide additional advice on how best to use electrical appliances to get maximum benefit from your new solar PV system.



What is required to participate in the Mega Solar evaluation

- You must have a solar PV system installed under the Mega Solar Scheme
- You must have broadband internet which is kept on all the time
- You must be willing for the monitoring system to connect to your home WIFI
- If you switch internet service provider (ISP) during the evaluation, you must either link the monitoring system with your new WIFI router or inform Wakefield Council so someone can do this for you
- You must provide consent for NEA staff to be able to collect and analyse your household solar generation and electricity consumption through the system
- You must also agree that NEA staff can collect your electricity meter readings from you or allow us to obtain it directly from your supplier.

What will happen if I agree to take part in this study?

If you agree to take part, the installers will fit the more advanced solar PV inverter and set up the monitoring system so you will be able to use it yourself.

NEA staff will download solar generation and electricity consumption data from the monitoring system. They may also contact your electricity supplier for meter reading data if required (you will need to sign a form to allow us to do this).

You will be invited to take part in the end of project evaluation questionnaire to assess the benefits of the solar PV system. Once this has been completed, you will be entered into the prize draw.

NEA will produce a report on the performance of the solar PV systems and the benefits to the owners. All information in the report will be anonymised.

You will be able to keep the monitoring system for the solar PV which will enable you to check it is working correctly and help you use electrical appliances at times when they will be powered by the solar PV.

Data Protection

National Energy Action takes its responsibilities in relation to handling and storing personal data very seriously. All data processing done by NEA is in line with the General Data Protection Regulations and your personal data (your name, address & contact details) will only be used for the purposes that you have given your consent for. They will never be used for marketing purposes or shared with other organisations.

The information collected will be used in anonymous form to write a report about the project, to inform planning of similar future projects, and may be included in publications and presentations. Your name, address, and members of your household will not be identifiable. Only anonymised information will be available in reports and presentations.

You may withdraw from the study at any time without giving a reason. If you wish to withdraw, then please contact **Paul Rogers** at National Energy Action using any of the following methods:

Phone: [REDACTED]

Email: paul.rogers@nea.org.uk

Postal Address: NEA, 6th Floor, West One, Forth Banks, Newcastle upon Tyne, NE1 3PA



Action for Warm Homes

Who is involved in the project?

National Energy Action (NEA)

NEA is the national fuel poverty charity. We work to ensure that everyone can live in a warm, safe home. NEA's Innovation and Technical Evaluation team have worked on a variety of projects to test how well energy-related technologies such as insulation, solar PV and battery storage work, and the differences they make to households.

Project team and contact details

Relevant project members and their contact details are noted below.

N.B. As most staff are currently working from home, email and mobile phone may be the best ways to contact them.

National Energy Action

Paul Rogers

Innovation & Technical Evaluation Co-ordinator

paul.rogers@nea.org.uk

Mobile: [REDACTED]

Michael Hamer

Innovation & Technical Evaluation Manager

michael.hamer@nea.org.uk

Mobile: [REDACTED]

6.3. Appendix 3 - Data sheet for LuxPower LXP3600 hybrid inverter¹⁷

Solar Input

Max. DC Input Power: - 7000W
 Nominal DC Input Voltage: - 360V.d.c
 DC Input Voltage Range: - 100 - 550V.d.c
 MPPT Voltage Range: - 120 - 500V.d.c
 Start-up Voltage: - 140V.d.c
 MPPT Number: - 2
 Max. DC Input Current: - 12.5A/12.5A
 Max. Short-circuit Current: - 13.7A/13.7A
 Max. Input Power Per MTPP: - 4000W/4000W
 Max. Feedback Current to Array: - 0/0A

Battery Input/Output

Compatible Battery Type: - Lithium-ion/Lead-Acid
 Nominal Battery Voltage: - 48V.d.c
 Battery Voltage Range: - 40 - 60V.d.c
 Max. Charge/Discharge Current: - 80A/80A
 Max. Charge/Discharge Power: - 3600W/3600W
 Charging Curve: - 3-stages
 Max. Charge Voltage: - 59V
 DOD (lithium-ion/Lead Acid): - 80%/50%
 Capacity of Battery: - 2-20kWh

AC Input/Output

Nominal AC Output Power: - 3600W
 Max. AC Output Power: - 3600VA
 Max. AC Output Current: - 16A
 Nominal AC Voltage: - 230V
 Optional AC Voltage Range: - 180-270Vac
 Nominal AC Frequency: - 50Hz/60Hz
 AC Frequency Range: - 45-55Hz/55-65Hz
 Power Factor: - Adjustable 0.8 overexcited to 0.8 under excited
 THDI: - <3%
 Inrush Current: - 10A/10us
 Max. Output Fault Current: - 50A/20us
 Max. Output Over Current Protect: - 20A



¹⁷ LuxPower LXP3600 hybrid inverter specification, <https://www.luxpower.co.uk/lux-power-hybrid-controllers#Hybrid3600> (Accessed 15 May 23)